

Level Gage, Valve & Accessories CATALOG



JERGUSON®
A PRODUCT OF CLARK-RELIANCE

Fast Turnaround on Gage & Valve Assemblies

Series 20 and 32 gages with select 60 and 70L Series valve models are available to be shipped as quickly as three (3) business days.



Insure the Quality... *Without the Wait*

Replacement parts can be purchased directly from the OEM!

Place your order for any of our most requested parts by 2PM (Eastern time) and we'll ship it that day.

clark-reliance.com/parts



Valve Rebuild Kits

Glass Maintenance Kits



Valve Sets

Notice to Plant Operators
The use of non-Original Equipment Manufacturer parts (such as glass, gaskets, probes, modules, etc.) will void the Agency Approval (FM, UL, CSA, CRN, ABS, etc.), pressure/temperature rating, and warranty of this equipment. Clark-Reliance requires the use of OEM parts for all repairs on this product in order to maintain plant and personnel safety, and reliable operation.



Order direct from the manufacturer.

Contents

Liquid Level Gages

Your Best Choice – Jerguson®	4
Reflex vs Transparent Level Gages	6
Selection Chart	8
Series 300L Reflex & Transparent Gages.....	10
Series 20 Reflex & Transparent Gages.....	12
Series 32 Reflex & Transparent Gages.....	14
Series 40 Reflex & Transparent Gages.....	16
Series 51 Transparent Gages	18
Series L10 Reflex & Transparent Gages.....	20
Weld Pad Liquid Level Gages	22
Series NF Non-Frost Extensions	24
Process Steam Gage Assemblies	26
LumaStar™ Illuminator	28
LumaStar™ Offshore Illuminator	32
LumaStar™ Illuminator 24VDC.....	34
Coating Options	36
Spare Parts 34mm	37

Liquid Level Valves

360 Series Safety Ballcheck Valves	38
Traditional Safety Ballcheck Valves	40
140 Series Safety Ballcheck Valves	41
60 Series Safety Ballcheck Valves	42
70BL Series Safety Ballcheck Valves	43
70 Series Safety Ballcheck Valves	44
80H Series Safety Ballcheck Valves	45
86HO Safety Ballcheck Valves	46
90 Series Safety Ballcheck Valves	47
Valve Options	48
Tubular Glass Gages	49
Valves for Tubular Glass Gages	50
Tubular Gage Assembly Options (#136 & #56)....	51

Three Manufacturing Facilities and Over 150 Sales Representative Offices Worldwide



Why a Jerguson® Flat Glass Gage is Your Best Choice

Jerguson Flat Glass Gages are simple, rugged instruments engineered and built to give you accurate liquid level readings for the life of the vessel. The gages' special features make them safer, easier to service, and allow them to be re-machined to extend their life.

Our Recessed Gasket Surface: Easier Servicing, Safer, Re-Machineable

Jerguson gage chambers have a gasket "pocket" that makes it much easier to replace gaskets. This is appreciated during bench servicing, but is especially valuable in the field, where the recess provides a positive locating benefit, making it possible to replace gaskets on gages in-place.

A recessed gasket surface is also a safety feature that can minimize leaks or could even prevent a blowout. If the gage's bolts were to be improperly torqued, or under certain thermal expansion conditions, clamping pressure can be lost. If this happens, the gage's design will direct the fluid to push the gasket laterally outward and into the side wall of the pocket, rather than causing a gasket to blow-out.

The recessed gasket surface is re-machineable. Because the Jerguson gage chamber is a robust 1 9/16" thick, it can be re-milled rather than replaced if steam cuts or pitting occur. (Competitive gages cannot be re-machined because they are only 1 3/8" thick.)

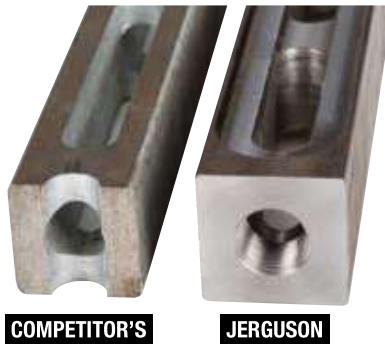

COMPETITOR'S

JERGUSON

Our recessed gasket surface makes our gages easier to service, safer, and re-machineable.





Shrouded Carbon Steel Covers to Protect the Glass Are Standard

Most Jerguson gages employ shrouded covers which protect both the glass and personnel. The shrouds protect the glass from sandblasting during re-painting — a frequent occurrence in offshore applications. Additionally, in the event of a leak, the shroud will deflect the stream to protect personnel who may be in the area.



Shrouded cover construction

Can Be Fitted With the First Explosion-Proof White LED Illuminator on the Market

The LumaStar™ EPL Series Illuminators are super bright, with an intense white light that cuts through dark fluids and dirt... way better than colored LEDs! With up to 100,000 hours of life and no heat generation, you'll clearly see fluid levels while saving money on electricity and maintenance.

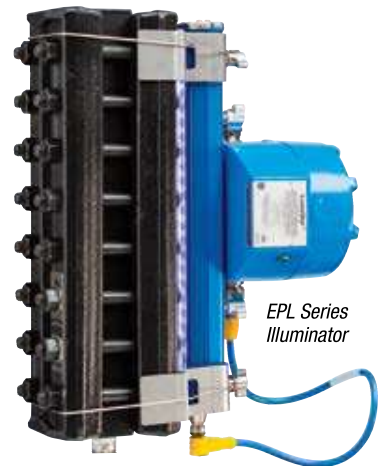

EPL Series Illuminator

Safe View™ Safety Shield for Extra Protection

Our new Safe View Safety Shield wraps around the gage to protect operators. Lexan® construction. Fits Series 20, 32, 300L and most flat gages from other manufacturers.



Safe View™ Safety Shield

All Materials are Listed in ASME or ASTM

To guarantee mechanical and chemical material properties, all materials used in Jerguson gages are listed in either ASME or ASTM. This is not universally the case for all manufacturers' similar gages.

Since 1905, World Leaders in Liquid Level Indication and Control

Reflex vs Transparent Level Gages

Reflex Level Gages

Jerguson® Reflex Level Gages are ideal for clean total level indication applications for refining, petrochemical and general use. The reflex prisms are molded and polished to provide a crisp silver-black bi-color indication of the fluid level. As light passes into the reflex glass, if there is fluid present, the light continues through the glass and impacts the back of the level gage, providing a black color for fluid level regardless of the actual color properties of the process fluid. If fluid is not present, the light never enters the chamber. It is reflected off the glass prisms back towards the viewer, providing a shiny silver or mirror like appearance to indicate the vapor space.



Reflex level gage showing about 60% oil



Reflex gage cross section

Advantages

- Economical
- Higher Pressure Ratings
- Silver/Black Indication
- For Clean Services

Transparent Level Gages

Jerguson® Transparent Level Gages are selected for interface level indication, dirty service or any application that requires the use of a shield to protect the glass from corrosion. A transparent gage is also known as a “thru-vision” gage since the gage is constructed with two pieces of flat polished glass assembled on opposite sides of the level gage chamber. Since the user can see straight through the gage, it is also easy to view the fluid properties, such as color, whereas this would not be possible with a reflex gage. The use of an illuminator is always recommended on a transparent gage, but especially in cases where the gage is elevated or in poor ambient light.



Transparent gage with illuminator showing 45% oil



Transparent gage cross section

Advantages

- Allows User to See Fluid Characteristics
- Used for Interface Applications
- Optional Mica or PCTFE (Kel-F®) Shields Available

Glass Types & Sizes

Glass Materials

- **Borosilicate**
 - Up to 600°F (316°C)
 - Up to 300 WSP
 - Over 300 WSP, Mica Protected Transparent Glass Only
- **HP Borosilicate**
 - Up to 600°F (316°C)
 - Higher Tolerances
- **Aluminosilicate**
 - Up to 800°F (426°C)

Glass Sizes – Industry Standard 34mm

Sizes 1 thru 9 (All models except 300L)

Size	Length	Typical Visible Range
1	4-1/2" (115mm)	3-3/4" (95mm)
2	5-1/2" (140mm)	4-3/4" (121mm)
3	6-1/2" (165mm)	5-3/4" (146mm)
4	7-1/2" (190mm)	6-3/4" (171mm)
5	8-5/8" (220mm)	7-7/8" (200mm)
6	9-7/8" (250mm)	9-1/8" (232mm)
7	11" (280mm)	10-1/4" (260mm)
8	12-5/8" (320mm)	11-7/8" (302mm)
9	13-3/8" (340mm)	12-5/8" (321mm)



Glass Sizes – Jerguson 25mm

Sizes 11 thru 20 (Series 300L - Obsolete 5 & 12)

Size	Length	Typical Visible Range
11	11" (280mm)	10-1/4" (260mm)
12	12" (305mm)	11-1/4" (286mm)
13	13" (330mm)	12-1/4" (311mm)
15	15" (381mm)	14-1/4" (362mm)
18	18" (457mm)	17-1/4" (438mm)
20	20" (508mm)	19-1/4" (489mm)

Specification

Materials of Construction

- Borosilicate Glass
- Gaskets
 - IFG®-5500 Standard (Seal/Cushion)
 - Graphite, with .002" (.05mm) stainless steel reinforcement layer
 - Teflon®
 - Other Materials Available

Chamber

- Carbon Steel
 - To -20°F (-28°C)
- Low Temp Carbon Steel
 - To -50°F (-45°C)
 - Charpy Impact Tested
 - B7M Bolts / 2HM Nuts
- Stainless Steel
 - To -325°F (-198°C)
 - Dual Rated 316/316L
- All Acceptable for NACE Service

Shields

Shields are used to protect the glass from chemical attack. Two shields are available: Mica and PCTFE.

Mica: Mica shields are used to protect the glass from corrosion in high pressure steam (over 300WSP) and caustic applications (pH >11).

PCTFE: PCTFE shields (formerly known as Kel-F®) are primarily used in Hydrofluoric Acid service. Note that the PCTFE shield also serves as the sealing gasket; no additional sealing gasket is required.



Gage Code for Jerguson Gages

Special Features
 M = Mica Shield
 K = PCTFE (Kel-F) Shield
 F = Non-frosting
 H = External Heating
 E = Electrical Heating
 T = Internal Heating
 CH = Close Hook-up (Side or Back Conns.)
 W = Weld Pad
 IW = Isolable Weld Pad

Glass Size Series 300L:
 11, 12, 13, 15, 18, 20

Other Series:
 1 thru 9

27-RFCH-20

Number of Sections: 27

Type of Glass: R = Reflex, T = Transparent

Series: 20, 32, 300L, L10, 40, 51

Gasket Materials — Standard Offering

Material	Min. Temperature	Max. Temperature	Rating Factor
Garlock IFG-5500	-40°F (-40°C)	550°F (288°C)	100%
25% Glass Filled TFE	-328°F (-200°C)	500°F (260°C)	100%
Grafoil®	-400°F (-240°C)	800°F (427°C)	100%
PCTFE (Kel-F®) Shield	-400°F (-240°C)	302°F (150°C)	50%

Reflex Type Selection Chart

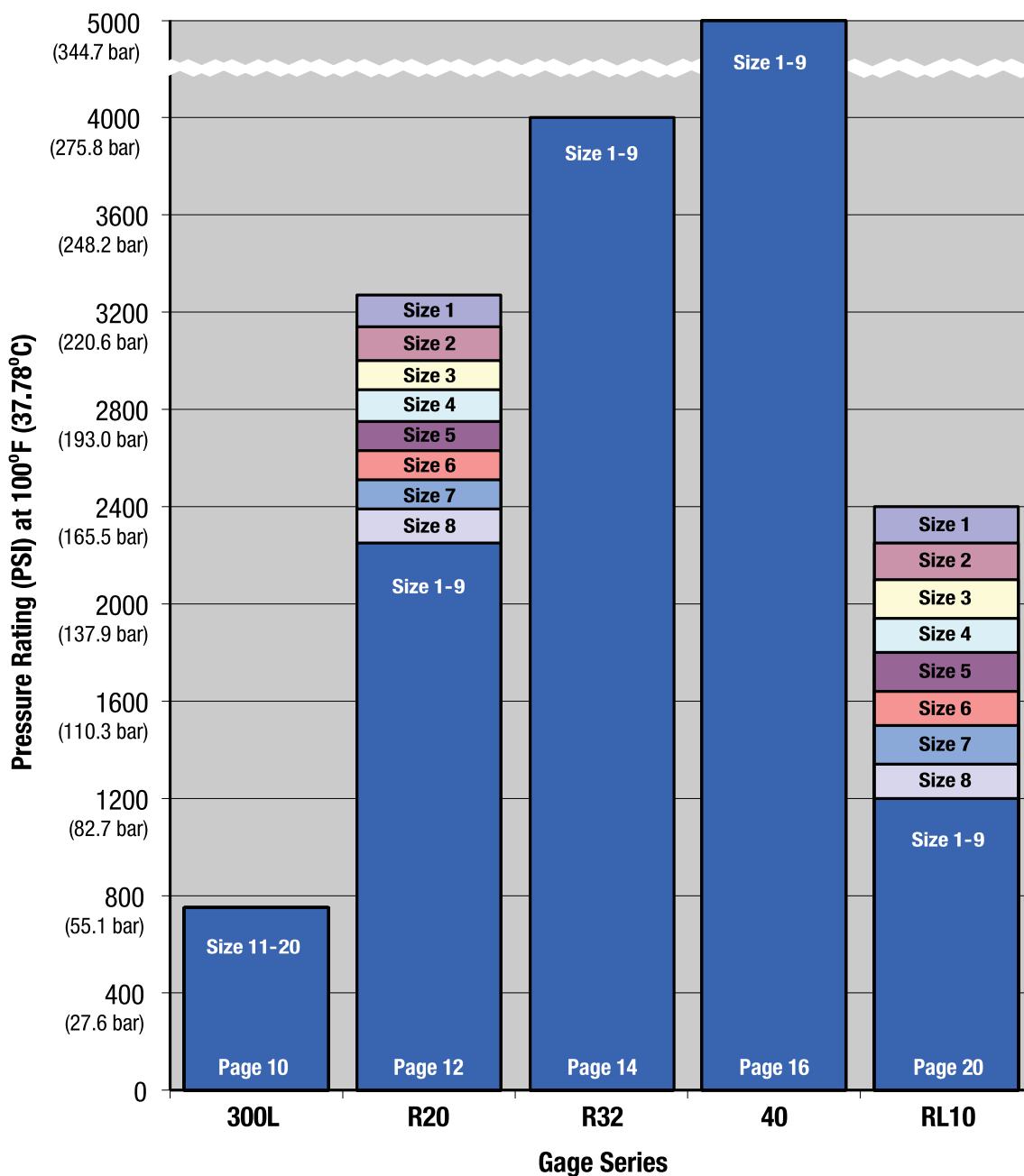

Transparent Type Selection Chart

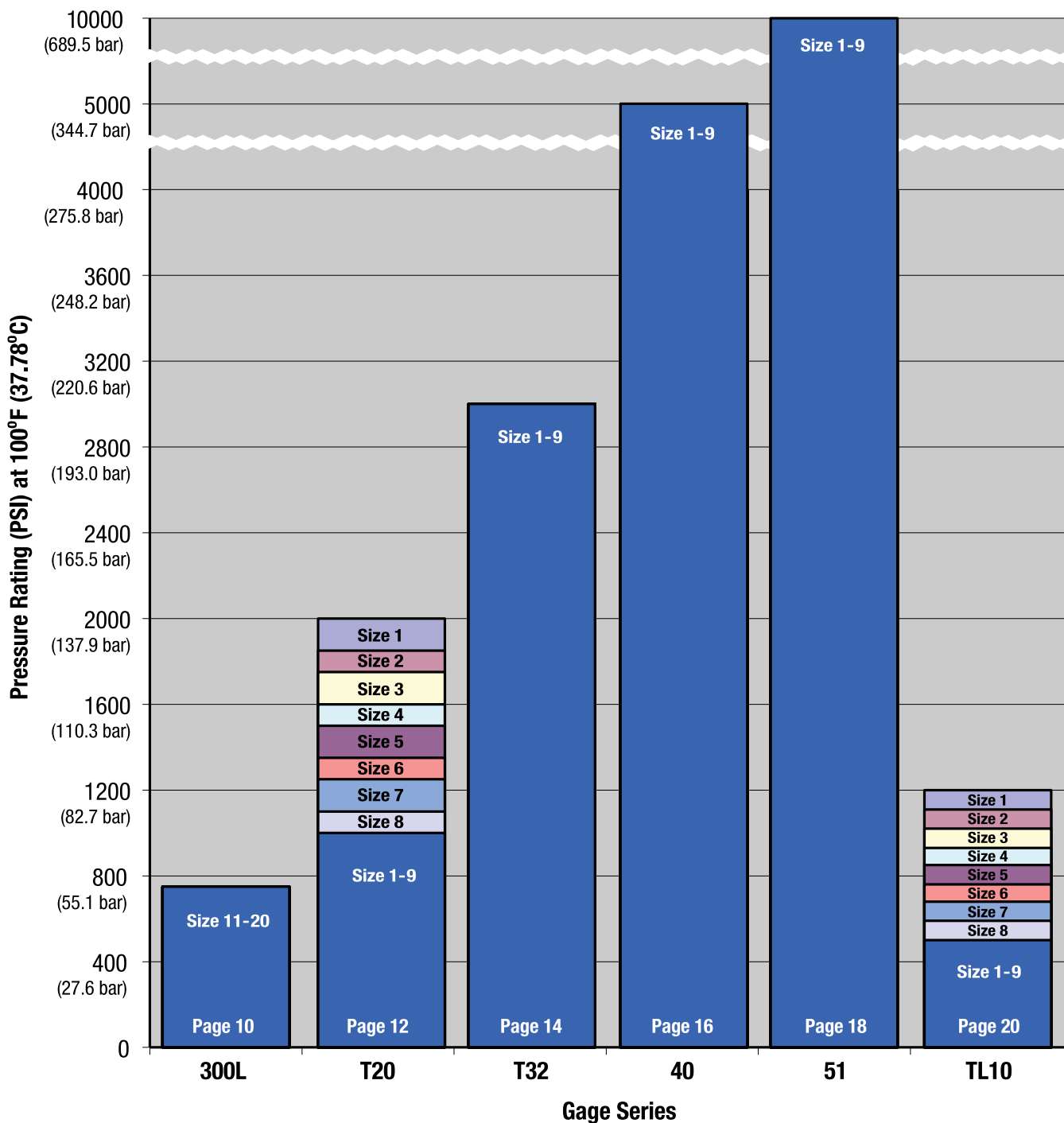



Reflex
R-300L



Transparent
T-300L

For Pressures Up to 300# ANSI

Series 300L

Features

- Recessed Gasket Seat in Chamber and Cover
- 25mm Glass, Size 11-20
- Economical 300# ANSI Gage
- Tempered Borosilicate Glass
- Wetted parts conform to NACE MR0175 & MR0103
- All parts listed in ASTM or ASME B31.3
- All Gages feature a continuous, one-piece chamber regardless of length

The Series 300L gage is an economical gage with increased visible ranges per gage section. This gage series uses the proprietary Jerguson 25mm glass, which is thinner, narrower and longer than traditional gage glass. The Series 300L features a recessed gasket surface, barstock non-shrouded covers and ASTM grade bolting. Due to the length of each gage section this model is not recommended for high pressure steam service.

Refer to page 24 for Non-Frost Extensions, page 28 for Illuminators, page 25 for Support Brackets, and page 7 for Mica Shields.

PRESSURE / TEMPERATURE RATINGS (PSI)

Carbon Steel Chamber

Temperature		Pressure	
°F	°C	PSI	BarG
100	38	750	51.7
200	93	750	51.7
300	149	730	50.3
400	204	705	48.6
500	260	665	45.9
600	316	605	41.7

Saturated Steam Rating 300 WSP

NOTE: Flanged gages are derated to flange rating, if applicable

TEST PRESSURE: All gages are hydrostatically tested by Jerguson prior to shipment @ 1 1/2 times the design pressure rating at 100°F (38°C).

PRESSURE / TEMPERATURE RATINGS (PSI)

Stainless Steel Chamber

Temperature		Pressure	
°F	°C	PSI	BarG
100	38	720	49.6
200	93	620	42.7
300	149	560	38.6
400	204	515	35.5
500	260	480	33.1
600	316	450	31.0

Saturated Steam Rating 300 WSP

NOTE: Flanged gages are derated to flange rating, if applicable

Liquid Level Gages

Series R-300L Reflex, Series T-300L Transparent

Sect. X Size	Visible Range		Overall Length (End Connected Gage Only)		Approximate Weight			
					Reflex, R-300L		Transp., T-300L	
	in	mm	in	mm	lbs.	Kgs	lbs.	Kgs
111	10.250	260	11.968	304	20	9.1	26	11.8
112	11.250	286	12.968	329	20	9.1	29	13.2
113	12.250	311	13.968	355	21	9.5	31	14.1
115	14.250	362	15.968	406	24	10.9	35	15.9
118	17.250	438	18.968	482	29	13.2	42	19.1
120	19.250	489	20.968	533	32	14.5	46	20.9
211	22.344	568	24.062	611	36	16.4	53	24.1
212	24.344	618	26.062	662	39	17.7	58	26.3
213	26.344	669	28.062	713	43	19.5	62	28.2
215	30.344	771	32.062	814	49	22.3	71	32.3
218	36.344	923	38.062	967	57	25.9	84	38.2
220	40.344	1025	42.062	1068	64	29.1	93	42.3
311	34.438	875	36.156	918	54	24.5	80	36.4
312	37.438	951	39.156	995	59	26.8	87	39.5
313	40.438	1027	42.156	1071	64	29.1	93	42.3
315	46.438	1180	48.156	1223	73	33.2	107	48.6
318	55.438	1408	57.156	1452	86	39.1	126	57.3
320	61.438	1561	63.156	1604	96	43.6	140	63.6
411	46.532	1182	48.250	1226	72	32.7	106	48.2
412	50.532	1284	52.250	1327	79	35.9	116	52.7
413	54.532	1385	56.250	1429	86	39.1	125	56.8
415	62.532	1588	64.250	1632	98	44.5	143	65.0
418	74.532	1893	76.250	1937	115	52.3	168	76.4
420	82.532	2096	84.250	2140	128	58.2	186	84.5
511	58.626	1489	60.344	1533	91	41.4	133	60.5
512	63.626	1616	65.344	1660	99	45.0	145	65.9
513	68.626	1743	70.344	1787	107	48.6	156	70.9
515	78.626	1997	80.344	2041	122	55.5	179	81.4
518	93.626	2378	95.344	2422	143	65.0	210	95.5
520	103.626	2632	105.344	2676	160	72.7	233	105.9
611	70.720	1796	72.438	1840	109	49.5	160	72.7
612	76.720	1949	78.438	1992	119	54.1	173	78.6
613	82.720	2101	84.438	2145	129	58.6	187	85.0
615	94.720	2406	96.438	2450	147	66.8	215	97.7
618	112.720	2863	114.438	2907	172	78.2	252	114.5
620	124.720	3168	126.438	3212	192	87.3	280	127.3

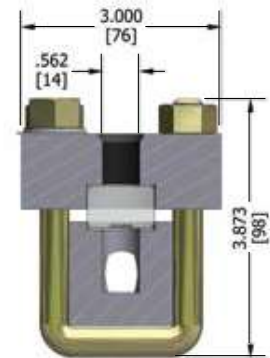

Series R-300L Reflex

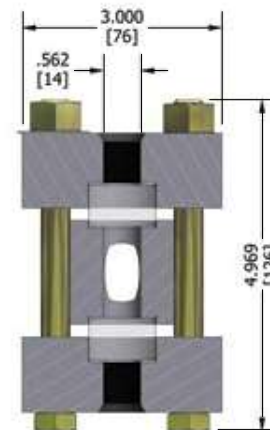

Series T-300L Transparent



CE models available



Specifications (See page 7 for Specifying Information)

SECTIONS LENGTHS

Gage sections are available in six standard glass sizes. Longer sizes are constructed with multiple vision slots in a continuous solid bar chamber.

CONNECTIONS

Standard connections are at top and bottom and are 1/2" and 3/4" NPT female. Optional connections are available, such as socket weld, flanged or close hook-up (side/side).

LIQUID CHAMBER

Machined from bar stock. The gasket seat is recessed to provide lateral support, and facilitate positioning of the gasket. This seat aids in field repair, and enhances safety/reliability.

COVERS

Carbon steel non-shrouded covers are standard with optional materials available. The cushion gasket surface is recessed on all covers.

BOLTS & NUTS

Steel fasteners, heat treated for strength; A193 B7 bolts / A194 2H nuts. NACE options include A193 B7M bolts / A194 2HM nuts (Transparent only) and A193 B8M bolts / A194 8M nuts (316 Stainless Steel).

GLASS

Tempered borosilicate is used to 600°F (316°C) Transparent glass may be protected from corrosive media with mica shields.

GASKETS

Standard gaskets are precision die-cut in proprietary Jerguson® dies.

FINISH

All carbon steel parts are finish coated prior to assembly with Jerguson Protective FP-16. Optional coatings such as FP-11 offshore available.

VALVES

Use of Jerguson gage valves is strongly recommended. Standard features include safety ballchecks which help prevent loss of product and physical injury in the event of a catastrophic failure.

Series 20 Reflex & Transparent Gages



Reflex
R-20

Transparent
T-20

TEST PRESSURE: All gages are hydrostatically tested by Jerguson prior to shipment @ 1 1/2 times the design pressure rating at 100°F (38°C).

For Pressures Up to 3270 PSI @ 100°F

Series 20

Features

- Recessed Gasket Seat in Chamber and Cover
- Tempered Borosilicate Glass conforming to BS3463, JIS B8211, & DIN 7081
- Wetted Parts conform to NACE MR0175 & MR0103
- All parts listed in ASTM & ASME B31.3
- ABS Certified
- Carbon Steel Covers are Shrouded to Protect the Glass Edges
- All Gages feature a continuous, one-piece chamber regardless of length

The Jerguson Series 20 gage is the most common gage specified and will cover 80-85% of applications encountered. Important features include a recessed gasket surface (standard on all gage series) and shrouded covers. A recessed gasket surface provides positive location of the seal gasket during both assembly and field repair and also makes it possible to repair a Jerguson gage while it is mounted to the vessel. The recessed gasket surface is also an important safety feature in the fact that it contains the gasket and helps prevent lateral movement which could lead to a gasket blow-out (as with competitive gages.)

Refer to page 24 for Non-Frost Extensions, page 28 for Illuminators, page 25 for Support Brackets, PCTFE Shields and page 7 for Mica Shields, and special alloys.

PRESSURE / TEMPERATURE RATINGS, PSI

Temperature		R-20 REFLEX GAGE								
		Glass Size								
°F	°C	1	2	3	4	5	6	7	8	9
100	38	3270	3140	3000	2880	2750	2630	2510	2390	2250
200	93	3090	2970	2860	2740	2620	2500	2380	2260	2150
300	149	2900	2790	2670	2560	2450	2340	2220	2110	2000
400	204	2700	2600	2490	2380	2270	2170	2060	1950	1850
500	260	2510	2410	2305	2205	2100	2000	1900	1800	1700
600	316	2285	2190	2100	2010	1915	1820	1730	1640	1550
For temperatures above 600°F (316°C) Aluminosilicate Glass must be used										
700	371	2080	1990	1910	1820	1740	1650	1570	1480	1400
800	427	1870	1790	1720	1640	1560	1480	1410	1330	1250
Saturated Steam Rating 300 WSP										

NOTE: Flanged gages are derated to flange rating, if applicable.

Temperature		T-20 TRANSPARENT GAGE								
		Glass Size								
°F	°C	1	2	3	4	5	6	7	8	9
100	38	2000	1850	1750	1600	1500	1350	1250	1100	1000
200	93	1900	1780	1660	1550	1440	1300	1175	1060	950
300	149	1770	1660	1550	1450	1330	1220	1100	1000	900
400	204	1675	1575	1470	1350	1250	1150	1050	925	850
500	260	1530	1450	1350	1250	1150	1050	950	850	750
600	316	1350	1275	1180	1100	1010	925	850	750	675
For temperatures above 600°F (316°C) Aluminosilicate Glass must be used										
700	371	1220	1140	1070	990	920	840	760	690	610
800	427	1100	1030	960	890	820	750	690	620	550
Saturated Steam Rating with MICA										
		600	600	600	600	550	500	450	400	350

Saturated Steam Rating 300 WSP NOTE: Flanged gages are derated to flange rating, if applicable.

PRESSURE / TEMPERATURE RATINGS, BarG

Temperature		R-20 REFLEX GAGE								
		Glass Size								
°F	°C	1	2	3	4	5	6	7	8	9
100	38	225.5	216.5	206.8	198.6	189.6	181.3	173.1	164.8	155.1
200	93	213.0	204.8	197.2	188.9	180.6	172.4	164.1	155.8	148.2
300	149	199.9	192.4	184.1	176.5	168.9	161.3	153.1	145.5	137.9
400	204	186.2	179.3	171.7	164.1	156.5	149.6	142.0	134.4	127.6
500	260	173.1	166.2	158.9	152.0	144.8	137.9	131.0	124.1	117.2
600	316	157.5	151.0	144.8	138.6	132.0	125.5	119.3	113.1	106.9
For temperatures above 600°F (316°C) Aluminosilicate Glass must be used										
700	371	143.4	137.2	131.7	125.5	120.0	113.8	108.2	102.0	96.5
800	427	128.9	123.4	118.6	113.1	107.6	102.0	97.2	91.7	86.2
Saturated Steam Rating 300 WSP										

NOTE: Flanged gages are derated to flange rating, if applicable.

Temperature		T-20 TRANSPARENT GAGE								
		Glass Size								
°F	°C	1	2	3	4	5	6	7	8	9
100	38	137.9	127.6	120.7	110.3	103.4	93.1	86.2	75.8	68.9
200	93	131.0	122.7	114.5	106.9	99.3	89.6	81.0	73.1	65.5
300	149	122.0	114.5	106.9	100.0	91.7	84.1	75.8	68.9	62.1
400	204	115.5	108.6	101.4	93.1	86.2	79.3	72.4	63.8	58.6
500	260	105.5	100.0	93.1	86.2	79.3	72.4	65.5	58.6	51.7
600	316	93.1	87.9	81.4	75.8	69.6	63.8	58.6	51.7	46.5
For temperatures above 600°F (316°C) Aluminosilicate Glass must be used										
700	371	84.1	78.6	73.8	68.3	63.4	57.9	52.4	47.6	42.1
800	427	75.8	71.0	66.2	61.4	56.5	51.7	47.6	42.7	37.9
Saturated Steam Rating with MICA										
		41.4	41.4	41.4	41.4	37.9	34.5	31.0	27.6	24.1

Saturated Steam Rating 300 WSP NOTE: Flanged gages are derated to flange rating, if applicable.

Liquid Level Gages

Series R-20 Reflex, Series T-20 Transparent

Sect. X Size	Visible Range		Overall Length (End Connected Gage Only)		Approximate Weight			
					Reflex, R-20		Transp., T-20	
	in	mm	in	mm	lbs.	Kgs	lbs.	Kgs
11	3.750	95	5.250	133	9	4.1	13	5.9
12	4.750	121	6.250	159	10	4.5	15	6.8
13	5.750	146	7.250	184	12	5.5	17	7.7
14	6.750	171	8.250	210	13	5.9	20	9.1
15	7.875	200	9.375	238	15	6.8	22	10.0
16	9.125	232	10.625	270	17	7.7	25	11.4
17	10.250	260	11.750	298	19	8.6	28	12.7
18	11.875	302	13.375	340	21	9.5	31	14.1
19	12.625	321	14.125	359	22	10.0	33	15.0
23	13.000	330	14.500	368	23	10.5	35	15.9
24	15.000	381	16.500	419	27	12.3	39	17.7
25	17.250	438	18.750	476	29	13.2	44	20.0
26	19.750	502	21.250	540	34	15.5	50	22.7
27	22.000	559	23.500	597	37	16.8	55	25.0
28	25.250	641	26.750	679	42	19.1	62	28.2
29	26.750	679	28.250	718	44	20.0	65	29.5
36	30.375	772	31.875	810	50	22.7	75	34.1
37	33.750	857	35.250	895	56	25.5	82	37.3
38	38.625	981	40.125	1019	63	28.6	93	42.3
39	40.875	1038	42.375	1076	66	30.0	98	44.5
47	45.500	1156	47.000	1194	74	33.6	109	49.5
48	52.000	1321	53.500	1359	84	38.2	124	56.4
49	55.000	1397	56.500	1435	88	40.0	130	59.1
57	57.250	1454	58.750	1492	93	42.3	137	62.3
58	65.375	1661	66.875	1699	105	47.7	155	70.5
59	69.125	1756	70.625	1794	111	50.5	163	74.1
68	78.750	2000	80.250	2038	126	57.3	186	84.5
69	83.250	2115	84.750	2153	133	60.5	196	89.1
78	92.125	2340	93.625	2378	147	66.8	217	98.6
79	97.375	2473	98.875	2511	155	70.5	228	103.6
88	105.500	2680	107.000	2718	169	76.8	248	112.7
89	111.500	2832	113.000	2870	177	80.5	261	118.6
98	118.875	3019	120.375	3058	190	86.4	279	126.8
99	125.625	3191	127.125	3229	199	90.5	294	133.6

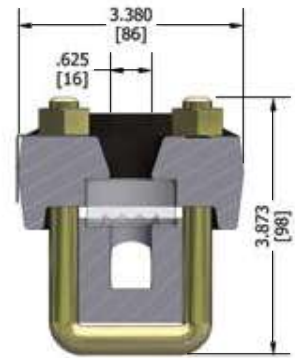

Series R-20 Reflex

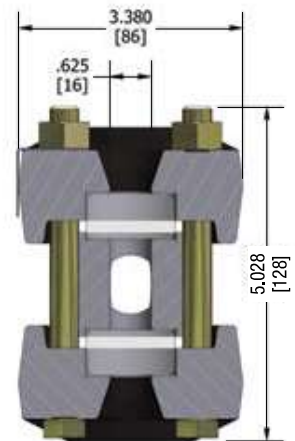

Series T-20 Transparent



CE models available



Specifications (See page 7 for Specifying Information)

SECTION LENGTHS

Gage sections are available in nine standard glass sizes. Longer sizes are constructed with multiple vision slots in a continuous solid bar chamber.

CONNECTIONS

Standard connections are at top and bottom and are 1/2" or 3/4" NPT female. Optional connections are available, such as socket weld, flanged or close hook-up (side/side).

LIQUID CHAMBER

Machined from bar stock. The gasket seat is recessed to provide lateral support, and facilitate positioning of the gasket. This seat aids in field repair, and enhances safety/reliability.

COVERS

Forged carbon steel shrouded covers are standard with optional materials available. The cushion gasket surface is recessed on all covers.

BOLTS & NUTS

Steel fasteners, heat treated for strength; A193 B7 bolts / A194 2H nuts. NACE options include A193 B7M bolts / A194 2HM nuts (Transparent only) and A193 B8M bolts / A194 8M nuts (316 Stainless Steel).

GLASS

Tempered Borosilicate is used to 600°F (316°C). Aluminosilicate is used to 800°F (427°C). Transparent glass may be protected from corrosive media with mica or Neoflon PCTFE shields.

GASKETS

Standard gaskets are precision die cut in proprietary Jerguson® dies.

FINISH

All carbon steel parts are finish coated prior to assembly with Jerguson Protective FP-16. Optional coatings such as FP-11 offshore available.

VALVES

Use of Jerguson gage valves is strongly recommended. Standard features include safety ballchecks which help prevent loss of product and physical injury in the event of a catastrophic failure.

Series 32 Reflex & Transparent Gages



Reflex
R-32



Transparent
T-32

For Pressures Up To 4000 PSI @ 100°F

Series 32

Features

- Recessed Gasket Seat in Chamber and Cover
- Tempered Borosilicate Glass conforming to BS3463, JIS B8211, & DIN 7081
- Wetted Parts conform to NACE MR0175 & MR0103
- All parts listed in ASTM & ASME B31.3
- ABS Certified
- Carbon Steel Covers are Shrouded to Protect the Glass Edges
- All Gages feature a continuous, one-piece chamber regardless of length

A Series 32 gage appears very similar to a Series 20, except the Series 32 gage features mid-span supports or tie-bars to allow for increased pressure ratings. Note that the mid-span support is recessed. This is very important as other brands do not recess their mid-span support which causes a blind spot in the vision. A recessed gasket surface provides positive location of the seal gasket during both assembly and field repair and also makes it possible to repair a Jerguson gage while it is mounted to the vessel. The recessed gasket surface is also an important safety feature in the fact that it contains the gasket and helps prevent lateral movement which could lead to a gasket blow-out (as with competitive gages).

Refer to page 24 for Non-Frost Extensions, page 28 for Illuminators, page 25 for Support Brackets, PCTFE Shields, and page 7 for Mica Shields and special alloys.

PRESSURE / TEMPERATURE RATINGS, PSI (BarG)

REFLEX GAGE Glass Size 1-9			
Temperature		PSI	BarG
°F	°C		
100	38	4000	275.8
200	93	3890	268.2
300	149	3790	261.3
400	204	3700	255.1
500	260	3470	239.2
600	316	3080	212.4
For temperatures above 600°F (316°C) Aluminosilicate Glass <i>must</i> be used			
700	371	2690	185.5
800	427	2300	158.6
Saturated Steam Rating 300 WSP			

TRANSPARENT GAGE Glass Size 1-9			
Temperature		PSI	BarG
°F	°C		
100	38	3000	206.8
200	93	2920	201.3
300	149	2850	196.5
400	204	2780	191.7
500	260	2600	179.3
600	316	2310	159.3
For temperatures above 600°F (316°C) Aluminosilicate Glass <i>must</i> be used			
700	371	2020	139.3
800	427	1730	119.3
Saturated Steam Rating 750 WSP			

NOTE: Flanged gages are derated to flange rating, if applicable.

TEST PRESSURE: All gages are hydrostatically tested by Jerguson prior to shipment @ 1 1/2 times the design pressure rating at 100°F (38°C).

Liquid Level Gages

Series R-32 Reflex, Series T-32 Transparent

Sect. X Size	Visible Range		Overall Length (End Connected Gage Only)		Approximate Weight			
					Reflex, R-32		Transp., T-32	
	in	mm	in	mm	lbs.	Kgs	lbs.	Kgs
11	3.750	95	5.250	133	9	4.1	13	5.9
12	4.750	121	6.250	159	10	4.5	15	6.8
13	5.750	146	7.250	184	12	5.5	17	7.7
14	6.750	171	8.250	210	13	5.9	20	9.1
15	7.875	200	9.375	238	15	6.8	22	10.0
16	9.125	232	10.625	270	17	7.7	25	11.4
17	10.250	260	11.750	298	19	8.6	28	12.7
18	11.875	302	13.375	340	21	9.5	31	14.1
19	12.625	321	14.125	359	22	10.0	33	15.0
23	13.000	330	14.500	368	23	10.5	35	15.9
24	15.000	381	16.500	419	27	12.3	40	18.2
25	17.250	438	18.750	476	30	13.6	44	20.0
26	19.750	502	21.250	540	34	15.5	50	22.7
27	22.000	559	23.500	597	38	17.3	56	25.5
28	25.250	641	26.750	679	42	19.1	63	28.6
29	26.750	679	28.250	718	45	20.5	66	30.0
36	30.375	772	31.875	810	51	23.2	76	34.5
37	33.750	857	35.250	895	56	25.5	84	38.2
38	38.625	981	40.125	1019	64	29.1	94	42.7
39	40.875	1038	42.375	1076	67	30.5	99	45.0
47	45.500	1156	47.000	1194	75	34.1	112	50.9
48	52.000	1321	53.500	1359	85	38.6	126	57.3
49	55.000	1397	56.500	1435	89	40.5	133	60.5
57	57.250	1454	58.750	1492	94	42.7	140	63.6
58	65.375	1661	66.875	1699	106	48.2	158	71.8
59	69.125	1756	70.625	1794	111	50.5	166	75.5
68	78.750	2000	80.250	2038	128	58.2	189	85.9
69	83.250	2115	84.750	2153	134	60.9	199	90.5
78	92.125	2340	93.625	2378	149	67.7	221	100.5
79	97.375	2473	98.875	2511	156	70.9	233	105.9
88	105.500	2680	107.000	2718	170	77.3	253	115.0
89	111.500	2832	113.000	2870	178	80.9	266	120.9
98	118.875	3019	120.375	3058	190	86.4	279	126.8
99	125.625	3191	127.125	3229	199	90.5	294	133.6

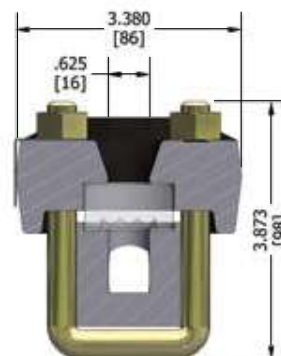

Series R-32 Reflex

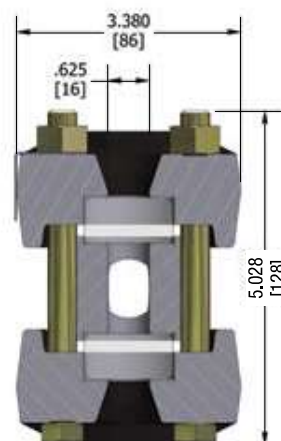

Series T-32 Transparent



CE models available



Specifications (See page 7 for Specifying Information)

SECTION LENGTHS

Gage sections are available in nine standard glass sizes. Longer sizes are constructed with multiple vision slots in a continuous solid bar chamber.

CONNECTIONS

Standard connections are at top and bottom and are 1/2" or 3/4" NPT female. Optional connections are available, such as socket weld, flanged or close hook-up (side/side).

LIQUID CHAMBER

Machined from bar stock. The gasket seat is recessed to provide lateral support, and facilitate positioning of the gasket. This seat aids in field repair, and enhances safety/reliability.

COVERS

Forged carbon steel shrouded covers are standard with optional materials available. The cushion gasket surface is recessed on all covers.

BOLTS & NUTS

Steel fasteners, heat treated for strength; A193 B7 bolts / A194 2H nuts. NACE options include A193 B7M bolts / A194 2HM nuts (Transparent only) and A193 B8M bolts / A194 8M nuts (316 Stainless Steel).

GLASS

Tempered Borosilicate is used to 600°F (316°C). Aluminosilicate is used to 800°F (427°C). Transparent glass may be protected from corrosive media with mica or Neoflon PCTFE shields.

GASKETS

Standard gaskets are precision die cut in proprietary Jerguson® dies.

FINISH

All carbon steel parts are finish coated prior to assembly with Jerguson Protective FP-16. Optional coatings such as FP-11 offshore available.

VALVES

Use of Jerguson gage valves is strongly recommended. Standard features include safety ballchecks which help prevent loss of product and physical injury in the event of a catastrophic failure.

Series 40 Reflex & Transparent Gages

For Pressures Up To 5000 PSI @ 100° F

Series 40

Features

- Recessed Gasket Seat in Chamber and Cover
- Tempered Borosilicate Glass conforming to BS3463, JIS B8211, & DIN 7081
- Wetted Parts conform to NACE MR0175 & MR0103
- All parts listed in ASTM & ASME B31.3
- ABS Certified
- All Gages feature a continuous, one-piece chamber regardless of length

The Series 40 gage is used in high pressure process applications or process steam to 1500 PSI. Note that both reflex and transparent gages have plain (transparent) glass. A reflex gage may be difficult to read with a clear fluid as you will not see a silver/black contrast.



Reflex
R-40



Transparent
T-40

SERIES 40 GAGE RATING (PSI)

SERIES 40		
Temperature °F	°C	CS & 316SS
100	38	5000
200	93	4685
300	149	4370
400	204	4055
500	260	3740
600	316	3425
For temperatures above 600°F (316°C) Aluminosilicate Glass <i>must</i> be used		
700	371	3110
800	427	2795

Saturated Steam Rating 1500 WSP

SERIES 40 GAGE RATING (BarG)

SERIES 40		
Temperature °F	°C	CS & 316SS
100	38	344.7
200	93	323.0
300	149	301.3
400	204	279.6
500	260	257.9
600	316	236.1
For temperatures above 600°F (316°C) Aluminosilicate Glass <i>must</i> be used		
700	371	214.4
800	427	192.7

Saturated Steam Rating 1500 WSP

TEST PRESSURE: All gages are hydrostatically tested by Jerguson prior to shipment @ 1 1/2 times the design pressure rating at 100°F (38°C).

Liquid Level Gages

Series R-40 Reflex, Series T-40 Transparent

Sect. X Size	Visible Range		Overall Length (End Connected Gage Only)		Approximate Weight			
	in	mm	in	mm	Reflex, R-40		Transp., T-40	
					lbs.	Kgs	lbs.	Kgs
SINGLE-SECTION GAGES								
11	3.625	92	7.250	184	20	9.1	28	12.7
12	4.625	117	8.250	210	22	10.0	32	14.5
13	5.625	143	9.250	235	25	11.4	35	15.9
14	6.625	168	10.250	260	27	12.3	38	17.3
15	7.750	197	11.375	289	30	13.6	42	19.1
16	9.000	229	12.625	321	34	15.5	47	21.4
17	10.125	257	13.750	349	37	16.8	52	23.6
18	11.750	298	15.375	391	41	18.6	57	25.9
19	12.500	318	16.125	410	43	19.5	60	27.3
TWO-SECTION GAGES								
23	14.875	378	18.500	470	50	22.7	70	31.8
24	16.875	429	20.500	521	54	24.5	76	34.5
25	19.125	486	22.750	578	60	27.3	84	38.2
26	21.625	549	25.250	641	68	30.9	94	42.7
27	23.875	606	27.500	699	74	33.6	104	47.3
28	27.125	689	30.750	781	82	37.3	114	51.8
29	28.625	727	32.250	819	86	39.1	120	54.5
THREE-SECTION GAGES								
36	34.250	870	37.875	962	102	46.4	141	64.1
37	37.625	956	41.250	1048	111	50.5	156	70.9
38	42.500	1080	46.125	1172	123	55.9	171	77.7
39	44.750	1137	48.375	1229	129	58.6	180	81.8
47	51.375	1305	55.000	1397	148	67.3	208	94.5
48	57.875	1470	61.500	1562	164	74.5	228	103.6
49	60.875	1546	64.500	1638	172	78.2	240	109.1

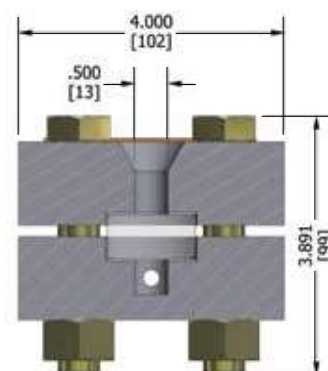

Series R-40 Reflex

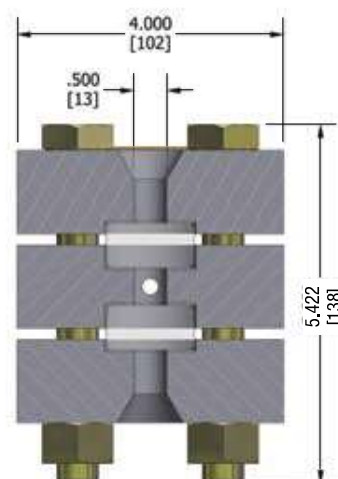

Series T-40 Transparent



CE models available

Specifications (See page 7 for Specifying Information)

LENGTHS

Gage sections are available in nine standard glass sizes. Longer sizes are constructed with multiple vision slots in a continuous solid bar chamber.

CONNECTIONS

Standard connections are at top and bottom and are 1/2" or 3/4" NPT female. Optional connections are available, such as socket weld, flanged or close hook up (side/side).

LIQUID CHAMBER

Machined from bar stock. The gasket seat is recessed to provide lateral support, and facilitate positioning of the gasket. This seat aids in field repair, and enhances safety/reliability.

COVERS

Carbon steel non-shrouded covers are standard with optional materials available. The cushion gasket surface is recessed on all covers.

BOLTS & NUTS

Steel fasteners, heat treated for strength; A193 B7 bolts / A194 2H nuts. NACE option for A193 B8M bolts / A194 8M nuts (316 Stainless Steel).

GLASS

Tempered Borosilicate is used to 600°F (316°C). Aluminosilicate is used to 800°F (427°C). Transparent glass may be protected from corrosive media with mica or Neoflon PCTFE shields.

GASKETS

Standard gaskets are precision die cut in proprietary Jerguson® dies.

FINISH

All carbon steel parts are finish coated prior to assembly with Jerguson Protective FP-16. Optional coatings such as FP-11 offshore available.

VALVES

Use of Jerguson gage valves is strongly recommended. Standard features include safety ballchecks which help prevent loss of product and physical injury in the event of a catastrophic failure.



**Transparent
T-51**

For Pressures Up To 10,000 PSI @ 100°F

Series 51

Features

- Tempered Borosilicate Glass conforming to BS3463, JIS B8211, & DIN 7081
- Available Transparent Only
- Ported Gage with O-Ring Seals
- All gages feature a continuous, one-piece chamber regardless of length

The Jerguson Series 51 Liquid Level Gage is a specially designed instrument capable of withstanding high pressures. The one-piece chamber is machined out of solid bar stock carbon steel or stainless steel as specified. It is drilled lengthwise and crosswise at each port leaving tie-bars in between to resist deflection under pressure. Viton® O-Rings that seal each port are unaffected by most liquids that cause deterioration in rubber. The O-Rings are seated in recessed circular channels to assure proper sealing action.

Pressure/Temperature Ratings for
NPT Connections, PSI (BarG)

CARBON & STAINLESS STEEL			
Temperature		PSI	BarG
°F	°C		
100	38	6000	413.7
200	93	6000	413.7
300	149	6000	413.7
400	204	6000	413.7

Not recommended for steam service.

Pressure/Temperature Ratings
for Socket Weld or High Pressure
Connections, PSI (BarG)

CARBON & STAINLESS STEEL			
Temperature		PSI	BarG
°F	°C		
100	38	10000	689.5
200	93	10000	689.5
300	149	10000	689.5
400	204	10000	689.5

Not recommended for steam service.

Liquid Level Gages

Series 51

Sect. X Size	Visible Range		Overall Length (End Connected Gage Only)		Approximate Weight		No. of Ports
	in	mm	in	mm	lbs.	Kgs	
SINGLE-SECTION GAGES							
11	3.625	92	6.500	165	31	14.0	5
12	4.437	113	7.500	191	35	16.0	6
13	5.250	133	8.500	216	39	17.5	7
14	6.062	154	9.500	241	42	19.0	8
15	7.687	195	10.625	270	46	21.0	10
16	8.500	216	11.875	302	52	23.5	11
17	10.125	257	13.000	330	57	26.0	13
18	11.750	298	14.625	371	63	28.5	15
19	12.562	319	15.375	391	66	30.0	16
TWO-SECTION GAGES							
23	12.500	318	15.750	400	77	35.0	14
24	14.312	364	17.750	451	84	38.0	16
25	16.656	423	20.000	508	92	42.0	20
26	19.125	486	22.500	572	103	47.0	22
27	21.875	556	24.750	629	114	52.0	26
28	25.125	638	28.000	711	125	57.0	30
29	26.719	679	29.500	749	132	60.0	32
THREE-SECTION GAGES							
36	29.750	756	33.125	841	155	70.5	33
37	33.625	854	36.500	927	172	78.0	39
38	38.500	978	41.375	1051	188	85.5	45
39	40.875	1038	43.625	1108	198	90.0	48
FOUR-SECTION GAGES							
47	45.375	1153	48.250	1226	229	104.0	52
48	51.875	1318	54.750	1391	151	114.0	60
49	55.031	1398	57.750	1467	264	120.0	64

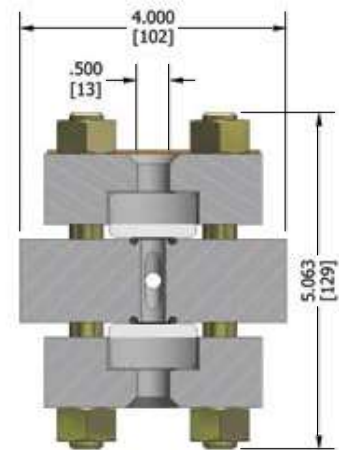

Series 51



CE models available



- NOTES: 1. Standard hydrotest pressure is 1.5 times the gage glass rated pressure, up to 10,000 PSI.
2. When ordering, state maximum working pressure – temperature.
3. When ordering spare or replacement glass, specify "H.P." and gage size.

Specifications (See page 7 for Specifying Information)

MAXIMUM VISIBILITY

This gage is unique in that it combines the strength to withstand very high pressures with a good degree of visibility. Port holes in the chamber are drilled on an angle for positive drainage of the port, thus preventing false level reading caused by liquid hang up.

RATINGS

Carbon steel and 316SS are rated for 6,000 PSI @ 400°F using Viton® O-Rings when NPT end-connections are specified.

Carbon steel and 316SS are rated for 10,000 PSI @ 400°F using Viton® O-Rings when socket weld or high pressure fittings are utilized.

CONNECTIONS

1/2" N.P.T. or Flanged to 6,000 PSI. High pressure fittings recommended for pressures over 6,000 PSI.

CHOICE OF LENGTHS

Series 51 Gages are offered in standard sizes up to 6 feet in length. They are built to order in greater lengths.

CONSTRUCTION

Chambers are machined from solid bar stock steel, carbon or stainless as specified. Covers are carbon steel. Studs are threaded through the chamber to allow glasses on each side to be changed individually.

Although the tempered longitudinal glass is carefully chosen for "close tolerance," the design of the chamber and individual self-sealing O-Rings at each port confine the pressure on the glass to 1/2" circles. Fibrous cushions are used between covers and glasses.

For Boiling/Flashing Liquids at Pressures Up To 2400 PSI @ 100°F (38°C)

Series L10



Reflex
RL-10

Transparent
TL-10

Features

- Recessed Gasket Seat in Chamber and Cover
- Tempered Borosilicate Glass conforming to BS3463, JIS B8211, & DIN 7081
- Wetted Parts conform to NACE MR0175 & MR0103
- All parts listed in ASTM or ASME B31.3
- ABS Certified
- All Gages feature a continuous, one-piece chamber regardless of length

Jerguson Large Chamber Gages are designed to give an accurate liquid level reading of liquids that have a tendency to surge or boil. These gages are highly effective in:

- (1) reducing the boiling effects of entrained gas being released under low pressure,
- (2) eliminating apparent level fluctuations that occur in standard gages (with small chambers) when boiling / flashing vapors try to rise to the surface, and
- (3) applications where the operating temperature is below freezing and high ambient temperatures cause the temperature of the fluid in the gage to exceed the boiling point of the liquid. In applications where the operating temperature is below freezing the gage must be equipped with Non-Frost Extensions.

Jerguson Large Chamber Gages are available in reflex or transparent design. The liquid chamber is constructed of heavy tubing, carefully slotted and machined to provide plane seats for the gaskets and glass assemblies. Standard covers are carbon steel secured with specially designed carbon steel bolts.

PRESSURE / TEMPERATURE RATINGS, PSI

Temperature	RL-10 REFLEX GAGE									
	Glass Size									
°F	°C	1	2	3	4	5	6	7	8	9
100	38	2400	2250	2100	1940	1800	1640	1500	1340	1200
200	93	2220	2090	1950	1810	1670	1540	1400	1260	1130
300	149	2050	1920	1800	1680	1540	1430	1300	1180	1060
400	204	1860	1750	1640	1530	1420	1320	1200	1100	1000
500	260	1690	1600	1500	1400	1300	1210	1110	1010	920
600	316	1520	1430	1350	1260	1180	1100	1010	920	850
For temperatures above 600°F (316°C) Aluminosilicate Glass <i>must</i> be used										
700	371	1340	1270	1200	1130	1060	990	920	850	780
800	427	1170	1110	1060	1000	940	880	830	770	710

Not recommended for steam service.

Temperature	TL-10 TRANSPARENT GAGE									
	Glass Size									
°F	°C	1	2	3	4	5	6	7	8	9
100	38	1200	1110	1020	930	850	760	680	590	500
200	93	1080	1000	920	840	760	680	600	530	450
300	149	960	890	830	750	680	620	540	470	400
400	204	850	790	720	670	600	540	480	420	360
500	260	730	680	630	570	520	470	420	360	310
600	316	620	570	530	480	440	400	360	310	270
For temperatures above 600°F (316°C) Aluminosilicate Glass <i>must</i> be used										
700	371	500	470	430	400	360	330	290	260	220
800	427	390	360	340	310	290	260	230	210	180

Not recommended for steam service.

PRESSURE / TEMPERATURE RATINGS, BarG

Temperature	RL-10 REFLEX GAGE									
	Glass Size									
°F	°C	1	2	3	4	5	6	7	8	9
100	38	165.5	155.1	144.8	133.8	124.1	113.1	103.4	92.4	82.7
200	93	153.1	144.1	134.4	124.8	115.1	106.2	96.5	86.9	77.9
300	149	141.3	132.4	124.1	115.8	106.2	98.6	89.6	81.4	73.1
400	204	128.2	120.7	113.1	105.5	97.9	91.0	82.7	75.8	68.9
500	260	116.5	110.3	103.4	96.5	89.6	83.4	76.5	69.6	63.4
600	316	104.8	98.6	93.1	86.9	81.4	75.8	69.6	63.4	58.6
For temperatures above 600°F (316°C) Aluminosilicate Glass <i>must</i> be used										
700	371	92.4	87.6	82.7	77.9	73.1	68.3	63.4	58.6	53.8
800	427	80.7	76.5	73.1	68.9	64.8	60.7	57.2	53.1	49.0

Not recommended for steam service.

Temperature	TL-10 TRANSPARENT GAGE									
	Glass Size									
°F	°C	1	2	3	4	5	6	7	8	9
100	38	82.7	76.5	70.3	64.1	58.6	52.4	46.9	40.7	34.5
200	93	74.5	68.9	63.4	57.9	52.4	46.9	41.4	36.5	31.0
300	149	66.2	61.4	57.2	51.7	46.9	42.7	37.2	32.4	27.6
400	204	58.6	54.5	49.6	46.2	41.4	37.2	33.1	29.0	24.8
500	260	50.3	46.9	43.4	39.3	35.9	32.4	29.0	24.8	21.4
600	316	42.7	39.3	36.5	33.1	30.3	27.6	24.8	21.4	18.6
For temperatures above 600°F (316°C) Aluminosilicate Glass <i>must</i> be used										
700	371	34.5	32.4	29.6	27.6	24.8	22.8	20.0	17.9	15.2
800	427	26.9	24.8	23.4	21.4	20.0	17.9	15.9	14.5	12.4

Not recommended for steam service.

TEST PRESSURE: All gages are hydrostatically tested by Jerguson prior to shipment @ 1 1/2 times the design pressure rating at 100°F (38°C).

Liquid Level Gages

Series RL-10 Reflex & Series TL-10 Transparent

Size No.	Visible Range		Overall Length		RL-10 Reflex Approximate Weight		TL-10 Transparent Approximate Weight	
	in	mm	in	mm	lbs.	Kgs	lbs.	Kgs
11	3.750	95	6.188	157	11	5.0	14	6.4
12	4.750	121	7.188	183	13	5.9	17	7.7
13	5.750	146	8.188	208	15	6.8	19	8.6
14	6.750	171	9.188	233	17	7.7	21	9.5
15	7.875	200	10.313	262	18	8.2	23	10.5
16	9.125	232	11.563	294	20	9.1	26	11.8
17	10.250	260	12.688	322	22	10.0	29	13.2
18	11.875	302	14.313	364	25	11.4	32	14.5
19	12.625	321	15.063	383	26	11.8	34	15.5
23	13.000	330	15.438	392	27	12.3	36	16.4
24	15.000	381	17.438	443	31	14.1	40	18.2
25	17.250	438	19.688	500	34	15.5	45	20.5
26	19.750	502	22.188	564	39	17.7	50	22.7
27	22.000	559	24.438	621	43	19.5	55	25
28	25.250	641	27.688	703	48	21.8	62	28.2
29	26.750	679	29.188	741	51	23.2	65	29.5
36	30.375	772	32.813	833	57	25.9	74	33.6
37	33.750	857	36.188	919	63	28.6	82	37.3
38	38.625	981	41.063	1043	71	32.3	92	41.8
39	40.875	1038	43.313	1100	75	34.1	97	44.1
47	45.500	1156	47.938	1218	84	38.2	108	49.1
48	52.000	1321	54.438	1383	95	43.2	122	55.5
49	55.000	1397	57.438	1459	99	45.0	129	58.6
57	57.250	1454	59.688	1516	104	47.3	135	61.4
58	65.375	1661	67.813	1722	118	53.6	153	69.5
59	69.125	1756	71.563	1818	123	55.9	161	73.2
68	78.750	2000	81.188	2062	141	64.1	183	83.2
69	83.250	2115	85.688	2176	148	67.3	192	87.3
78	92.125	2340	94.563	2402	164	74.5	213	96.8
79	97.375	2473	99.813	2535	172	78.2	224	101.8
88	105.500	2680	107.938	2742	187	85.0	243	110.5
89	111.500	2832	113.938	2894	196	89.1	256	116.4

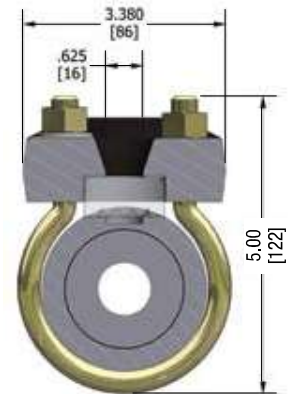

Series RL-10 Reflex

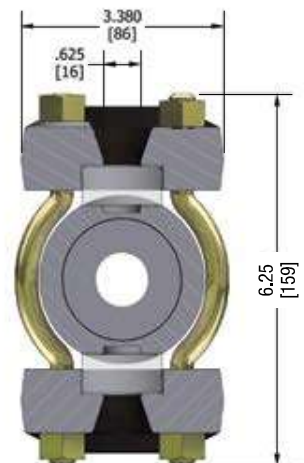

Series TL-10 Transparent



CE models available



Specifications (See page 7 for Specifying Information)

LENGTHS

Gage sections are available in 9 standard glass sizes. Longer sizes are constructed with multiple vision slots in a continuous solid tube chamber.

CONNECTIONS

Standard connections are at top and bottom and are 1/2" or 3/4" NPT female. Up to 2" NPT or socket weld end, side, or back connections are also available.

LIQUID CHAMBER

Heavy wall tubing, 2" inside diameter. Gasket seats are machined on the face of the chamber and assembly torques are designed to prevent sidewise movement of gasket.

COVERS

Forged carbon steel non-shrouded covers are standard with optional materials available. The cushion gasket surface is recessed on all covers.

BOLTS & NUTS

Steel fasteners, heat treated for strength; A193 B7 bolts / A194 2H nuts. NACE options include A193 B7M bolts / A194 2HM nuts (Transparent only) and A193 B8M bolts / A194 8M nuts (316 Stainless Steel).

GLASS

Tempered Borosilicate is used to 600°F (316°C). Aluminosilicate is used to 800°F (427°C). Transparent glass may be protected from corrosive media with mica or Neoflon PCTFE shields.

GASKETS

Standard gaskets are precision die cut in proprietary Jerguson® dies.

FINISH

All carbon steel parts are finish coated prior to assembly with Jerguson Protective FP-16. Optional coatings such as FP-11 offshore available.

VALVES

Use of Jerguson gage valves is strongly recommended. Standard features include safety ballchecks which help prevent loss of product and physical injury in the event of a catastrophic failure.



W20

Weld Pad Gages for Economical Level Indication on Non-Critical Applications

Series W20 & W300L

Features

- Applied directly to tank
- User must determine if acceptable for ASME Sec. VIII
- Recessed Gasket Seat in Chamber and Cover
- Tempered Borosilicate Glass conforming to BS3463, JIS B8211, & DIN 7081
- Wetted Parts conform to NACE MR0175 & MR0103
- All parts listed in ASTM & ASME B31.3

Standard Weld Pad Gages

Available in both reflex and transparent types. Generally used for non-critical applications. When using standard weld pad gages, the tank must be relieved of pressure and drained to service the gage. Seal pots are a typical application. This type of gage is not used on critical process equipment because you cannot perform maintenance or replace a gage without shutting down the entire process.

Isolable Weld Pad Gages

Jerguson Isolable Weld Pad Gages follow the general design of standard Jerguson weld pad gages but offer the additional advantages of integral valves. Because the gage can be isolated from the vessel by the valves, gaskets or glass can be replaced without lowering the level of liquid below the gage inlet or relieving pressure from the vessel. Isolable gages are installed by matching the valve inlets with holes drilled in the vessel and making a 100% fillet weld between the vessel wall and the valve inlets. The gage chamber is tack welded to the vessel.



Type RIW Isolable

Liquid Level Gages

Series RW-300L Reflex & Series TW-300L Transparent

Size No.	Visible Range		Overall Length		Approximate Weight	
	in	mm	in	mm	lbs.	Kgs
115	14.250	362	16.094	409	27	12.3
118	17.250	438	19.094	485	32	14.5
120	19.250	489	21.094	536	35	15.9
215	30.344	771	32.188	818	54	24.5
218	36.344	923	38.188	970	64	29.1
220	40.344	1025	42.188	1072	70	31.8
315	46.438	1180	48.281	1226	81	36.8
318	55.438	1408	57.281	1455	96	43.6
320	61.438	1561	63.281	1607	105	47.7
415	62.532	1588	64.375	1635	108	49.1
418	74.532	1893	76.375	1940	128	58.2
420	82.532	2096	84.375	2143	140	63.6

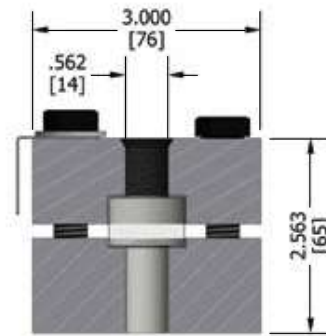

Series W-300L

Series RW-20 Reflex & Series TW-20 Transparent

Size No.	Visible Range		Overall Length		Approximate Weight	
	in	mm	in	mm	lbs.	Kgs
11	3.750	95	5.250	133	9	4.1
12	4.750	121	6.250	159	11	5.0
13	5.750	146	7.250	184	12	5.5
14	6.750	171	8.250	210	14	6.4
15	7.875	200	9.375	238	16	7.3
16	9.125	232	10.625	270	18	8.2
17	10.250	260	11.750	298	20	9.1
18	11.875	302	13.375	340	22	10.0
19	12.625	321	14.125	359	24	10.9
23	13.000	330	14.500	368	24	10.9
24	15.000	381	16.500	419	28	12.7
25	17.250	438	18.750	476	32	14.5
26	19.750	502	21.250	540	36	16.4
27	22.000	559	23.500	597	40	18.2
28	25.250	641	26.750	679	44	20.0
29	26.750	679	28.250	718	48	21.8
36	30.375	772	31.875	810	54	24.5
37	33.750	857	35.250	895	60	27.3
38	38.625	981	40.125	1019	66	30.0
39	40.875	1038	42.375	1076	72	32.7
47	45.500	1156	47.000	1194	80	36.4
48	52.000	1321	53.500	1359	88	40.0
49	55.000	1397	56.500	1435	96	43.6

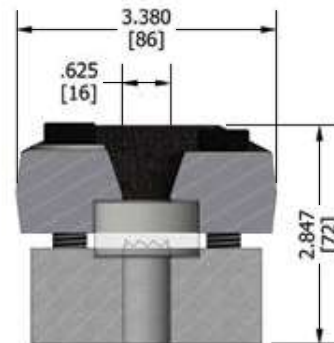

Series W-20

See page 7 for Specifying Information



Large Chamber Reflex Gage
(RF-L10 with Non-Frost Extension)



Non-Frost Extension maintains excellent visibility of liquid level in the event of heavy frost build-up on gage.

Non-Frost Extensions

Series NF

- Required for cryogenic installations, should extend 1/2" (12.7mm) beyond insulation
- Install on Reflex or Transparent types
- For use on standard or large chamber gages

For low temperature applications where frost has a tendency to build up on the gage or if cryogenic insulation is required, the Jerguson Non-Frost Extension keeps frost from covering the window and maintains clear visibility at all times.

The Jerguson Non-Frost Extension consists of a plastic extension which makes direct contact with the gage glass and extends beyond the cover so that the frost build-up does not obscure reading of the liquid level.

Mounting of the plastic extension is simple and can be accomplished without dismantling the gage. The Non-Frost Extension can be installed or removed (for cleaning), either before or after the gage has been put into service.

Available on Standard or Large Chamber Gages

Non-Frost Extensions have been designed for the Series 20, 32, and L-10 gages.

NON-FROST EXTENSIONS

P/N	°F	°C	in	mm
S18826-	-100	-73	4 5/8	117

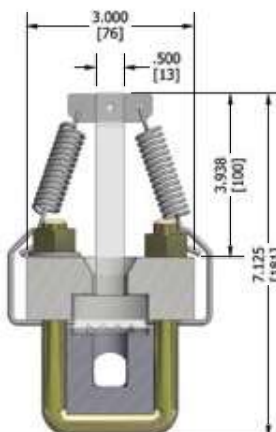

Series RF-20

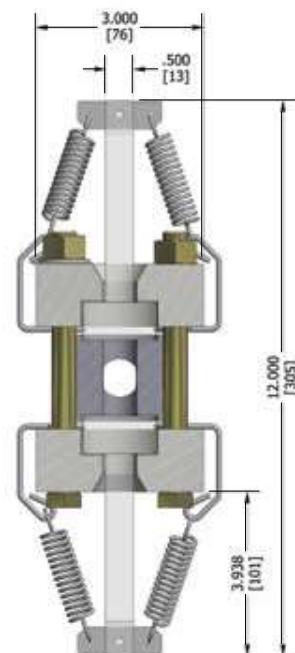

Series TF-20

General Information

General Material Recommendations

TEMPERATURE RANGE TO MINUS 20°F (-28°C)

Series 20, 32 and large chamber L-10
Gages with standard carbon steel
construction suitable to minus 20°F (-28°C).

Bolts A193, Grade B7

Nuts A194, Grade 2H

TEMPERATURE RANGE MINUS 20°F (-28.8°C) TO MINUS 50°F (-45°C)

Series 20 and 32 Gages

Chamber -50°F (-45°C) impact tested
low temp carbon steel

Covers -50°F (-45°C) impact tested
low temp carbon steel

Bolts A193, Grade B7M (for reflex gages use B8M)

Nuts A194, Grade 2HM (for reflex gages use B8M)

Series L-10 Gages

Chamber 316/316LSS

Bolts A193, Grade B8M

Nuts A194, Grade 8M

Covers -50°F (-45°C) impact tested
low temp carbon steel

TEMPERATURE RANGE MINUS 51°F (-46°C) TO MINUS 325°F (-198.3°C)

Series 20 Gages

Chamber 316/316LSS

Covers 316/316LSS

Bolts A193, Grade B8M

Nuts A194, Grade 8M

Series L-10 Gages

Chamber (Seamless tube) 316/316LSS

Covers 316/316LSS

Bolts A193, Grade B8M

Nuts A194, Grade 8M

Chamber Material Options

Alloy 20

Hastelloy® C276

Monel®

Titanium

Duplex SS (22% Chrome)

Super-Duplex SS (25% Chrome)

Super-Stainless (SM0254)

Chrome-Moly (various grades)

Inconel®

AL-6XN

321SS

347SS

Zirconium

317SS

410SS

*Consult factory for materials not listed or for
special cover and bolt material options*

Options

SUPPORT BRACKETS

Jerguson® recommends welded support brackets (see right) on gages that exceed 165# in weight. Gages longer than (5) sections of transparent glass typically require a support bracket for Series 20 & 32. Higher pressure gages may require brackets at smaller lengths due to increased weight.

FIELD WELDING OF GAGES

Jerguson gages provided with socket-weld connections should be welded without the end-section of glass assembled, unless an extended chamber is provided. Note that if field disassembly of the gage is required then the glass & gaskets will need to be replaced, even if they were never in service.

OPTIONAL CONNECTIONS FOR GAGES

Additional connection types are available for Jerguson Glass Level Gages. Reference Jerguson drawing GD-1713 @ www.jerguson.com.

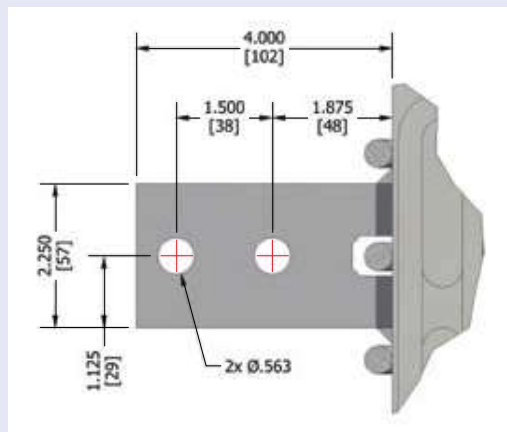

Gage Assemblies for Process Steam Applications to 1500 WSP

- High Safety Factor
- Less Danger of Mechanical Damage
- Constructed for Long Trouble-Free Service

Jerguson Process Steam Gage assemblies are designed for use on heat exchangers, steam traps, condensers and similar pressure vessel applications. **They are not for use on boilers for ASME Sec. I code applications.**

On all gages for steam or condensate service over 300 WSP, gage glasses are protected by mica shields. This protects the glass from the corrosive and erosive effects of the boiler or water and extends the service life of the glass.

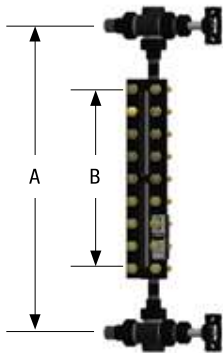

R-300L with #67 Valves

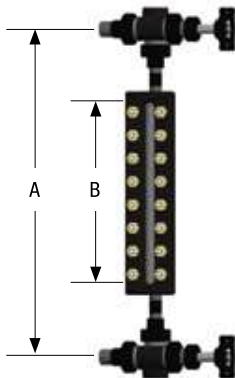

R-20 with #67 Valves

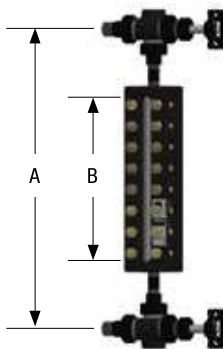

TM-20 with #67 Valves

Pressure to 300 WSP

Series R-300L Gage, No. 67 P/C Valves

Gage Size	Min. A Dim.	Dim. B	Rating
111-R-300L	17.47	10 1/4	300 WSP
112-R-300L	18.47	11 1/4	
113-R-300L	19.47	12 1/4	
115-R-300L	21.47	14 1/4	
118-R-300L	24.47	17 1/4	
120-R-300L	26.47	19 1/4	

Pressure to 300 WSP

Series R-20 Gage, No. 67 P/C Valves

Gage Size	Dim. A	Dim. B	Rating
11-R-20	10.75	3 3/4	300 WSP
12-R-20	11.75	4 3/4	
13-R-20	12.75	5 3/4	
14-R-20	13.75	6 3/4	
15-R-20	14.88	7 7/8	
16-R-20	16.13	9 1/8	
17-R-20	17.25	10 1/4	
18-R-20	18.88	11 7/8	
19-R-20	19.63	12 5/8	

Pressure to 600 WSP

Series TM-20 Gage, No. 67 P/C Valves

Gage Size	Dim. A	Dim. B	Rating
11-TM-20	10.75	3 3/4	600 WSP
12-TM-20	11.75	4 3/4	600 WSP
13-TM-30	12.75	5 3/4	600 WSP
14-TM-30	13.75	6 3/4	600 WSP
15-TM-30	14.88	7 7/8	550 WSP
16-TM-30	16.13	9 1/8	500 WSP
17-TM-30	17.25	10 1/4	450 WSP
18-TM-30	18.88	11 7/8	400 WSP
19-TM-30	19.63	12 5/8	350 WSP

Liquid Level Gages

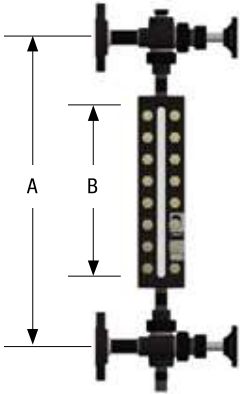

Pressure to 600 WSP

Series TM-32 Gage, No. 67 P/C Valves

Gage Size	Dim. A	Dim. B	Rating
15-TM-32	14.88	7 7/8	600 WSP
16-TM-32	16.13	9 1/8	
17-TM-32	17.25	10 1/4	
18-TM-32	18.88	11 7/8	
19-TM-32	19.63	12 5/8	

For pressures in the 600 WSP range, most operators prefer to see no threaded connection between the flanged vessel connection and the valve seat. The No. 67 valves are illustrated that have this feature. The vertical rising ballcheck is downstream from the seat providing accessibility without the necessity of disassembling the valve.

When multiple section gages are used, expansion loops are suggested to relieve piping strain.

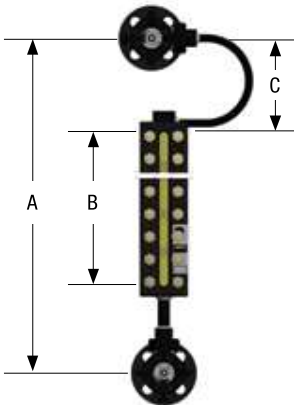

Pressure to 750 WSP

Series TM-32 Gage, No. 74BL Valves

Gage Size	Dim. A	Dim. B	Dim. C	Rating
11-TM-32	13	3 3/4	4 3/8	750 WSP
12-TM-32	14	4 3/4	4 3/8	
13-TM-32	15	5 3/4	4 3/8	
14-TM-32	16	6 3/4	4 3/8	
15-TM-32	17	7 7/8	4 1/4	
16-TM-32	18	9 1/8	4	
17-TM-32	19	10 1/4	3 7/8	
18-TM-32	21	11 7/8	4 1/4	
19-TM-32	22	12 5/8	4 1/2	

The thermal stresses that are prevalent at operating temperatures > 600 WSP make it advisable to furnish a built-in expansion loop. This expansion loop seeks to smooth out the pressure differential in the expansion rate between the vessel and gage glass by eliminating stresses in the assembly.

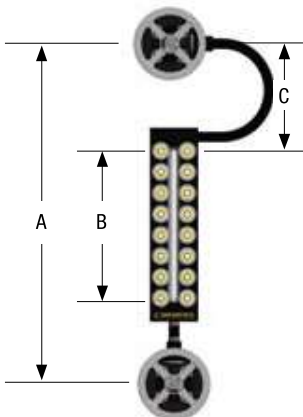

Pressure to 1500 WSP

Series TM-40 Gage, No. 74H Valves

Gage Size	Dim. A	Dim. B	Dim. C	Rating
11-TM-40	14	3 5/8	4 9/16	1500 WSP
12-TM-40	15	4 5/8	4 9/16	
13-TM-40	16	5 5/8	4 9/16	
14-TM-40	17	6 5/8	4 9/16	
15-TM-40	18	7 3/4	4 7/16	
16-TM-40	20	9	5 3/16	
17-TM-40	21	10 1/8	5 1/16	
18-TM-40	22	11 3/4	4 7/16	
19-TM-40	23	12 1/2	4 11/16	

For this high pressure series Jerguson® recommends a 74H valve which is specially designed for high pressure steam service. The stem has Acme threads to allow easier opening and stem operation, a loose knob construction for the disc and a stellited seat. The special spring washers used under the gage nuts absorb expansion and contraction and maintain the proper clamping load on the cover without retorquing the nuts.

See page 7 for Specifying Information

NOTE: Gages at pressures 600 WSP and above have spiral wound gasketed union gage connections.

STEAM RATINGS

The steam ratings are based on an operating temperature no higher than 25°F above the saturation temperature of the steam pressure at which the gage is rated. It has been determined that although operating temperatures in the shell of the vessel may be much higher, the temperature of

the steam rarely goes as high as 25°F over saturation temperature at the point of installation of the gage.

INSTALLATION CONSIDERATIONS

When installing multi-section gages in steam service, it is necessary to allow for differential expansion which may occur

between the vessel and the gage assembly. Expansion, if not compensated for, can cause severe stresses in the equipment and at connections. The use of expansion loops is recommended. On Jerguson Process Steam Gage assemblies for 750 WSP and higher, expansion loops are furnished integral with the gage chamber.

Without the Right Illumination, You Could Be In the Dark!



**A Typical Dirty Glass Level
Gage Without Illumination**

Case 1: Top of fluid level is between glass sections.



**Competitive Light A
(Green LED's)**

With the top of the fluid level right between the glass sections, your indicator could create a dangerous situation as the operator may easily think the gage was full or empty.



**Competitive Light B
(Amber LED's)**

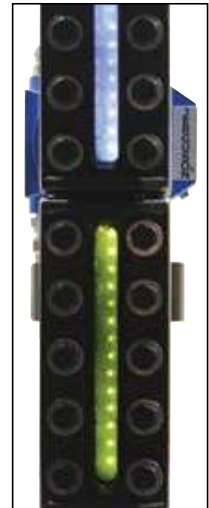

**Jerguson® LumaStar™
Illuminator (White LED's)**

High contrast illumination makes it easy to see that the level is between glass sections.

There's No Mistaking Your Level with a LumaStar™ Illuminator

Case 2: Top of fluid level is within a glass section.



**Competitive Light A
(Green LED's)**

With dirt on the glass, the level is not as clear. Your indicator could create a dangerous situation as the operator may easily think the gage was full or empty if viewing from a distance or in poor lighting conditions.

A colored LED can have the negative affect of "blending in" with the color of the process fluid, making it difficult to see the level.



**Competitive Light B
(Amber LED's)**



**Jerguson® LumaStar™
Illuminator (White LED's)**

Even with dirty glass, there is no doubt where the level is!

**Color is
Critical!**



EPL-100

LumaStar™ Illuminator Model EPL-100

The Ten-Year Solution: Anodized Aluminum Construction

Jerguson® LumaStar™ Illuminators' white LED design combines long-life performance with superior visibility for hazardous locations. Jerguson's Model EPL-100 is approved for use in Class I, Div 1, Group B, C & D and Zone 1 & 2 environments and available in sizes up to 58" long with a single power supply. That means a four section size nine or five section size seven gage from a single power supply at less than 250 mA! Contact your local representative or a Jerguson Applications Engineer to configure an EPL-100 for your transparent glass level gages.

- High Contrast
- *Superior Visibility Day or Night*
- Maintenance FREE
- Long Life ~100,000 hrs.
- No Heat Generation
- Field Upgradable
- *Fits any glass gage!*
- Eliminates "bulb-changes"
- Longest Field-of-View
- Covers up to 4 Size 9 Gage Sections or 5 Size 7 Gage Sections
- Explosion-Proof Power Supply, Intrinsically Safe Lighting Circuit
- Pays for itself in electricity savings alone!

"I purchased some 50 units of EPL-100 Illuminators for Chevron's Hawaii Refinery. The operators are very pleased with this unit as it radiates a tremendous amount of lighting through the gage glasses unlike the older incandescent types we had here. This makes verifying levels in columns, vessels, drums, etc. much easier. This is a good product and suited our needs perfectly."

- **Darin M. Matsumiya**,
I/E Supervisor/Analyst at
Chevron Texaco Hawaii

**24VDC option available,
see page 34**

Specifications – Model EPL-100

Power Supply:	115 or 230 VAC @ 50-60 Hz
Power Supply Weight:	5.2 lbs
Power Consumption:	<250 mA @ 120/240 VAC During Normal Operation Up to 400 mA max @ 120/240 VAC
Estimated Life:	100,000 Hours (continuous)
Agency Approvals:	FM and CSA Approvals <i>Class I, Div 1, Grps. B, C, & D, T4</i> ATEX Approvals Power Supply: II 2(2) G Ex d [ia] IIC T6 Light Strip: II 2 G Ex ia IIC T4
Wire Size:	Min 18 AWG / Max 12 AWG
Max Distance from Power Supply to Light Strip:	50 ft (15 m)
Ambient Temperature:	-40°F (-40°C) to 170°F (77°C)
Electrical Connection:	3/4" FNPT

Liquid Level Gages

LumaStar™ EPL-100

LumaStar Model EPL-100		Overall Length		Total Weight lbs.
Series 20/32	Series 300L	in	mm	
EPL-100-1_1		5.25	133	5.4
EPL-100-2_1		5.25	133	5.4
EPL-100-3_1		7.25	184	5.6
EPL-100-4-1		7.25	184	5.6
EPL-100-5_1		9.25	235	5.7
EPL-100-6_1	EPL-100-11_1	11.25	286	5.9
EPL-100-7_1		11.25	286	5.9
EPL-100-8_1	EPL-100-12_1	13.25	337	6.1
EPL-100-9_1	EPL-100-13_1	13.25	337	6.1
EPL-100-3_2	EPL-100-15_1	15.25	387	6.3
EPL-100-4_2		17.25	438	6.4
EPL-100-5_2	EPL-100-18_1	19.25	489	6.6
EPL-100-6_2	EPL-100-20_1	21.25	540	6.8
EPL-100-7_2	EPL-100-11_2	23.25	591	6.9
	EPL-100-12_2	25.25	641	
EPL-100-8_2	EPL-100-13_2	27.25	692	7.3
EPL-100-9_2		29.25	743	7.4
EPL-100-6_3	EPL-100-15_2	31.25	794	7.6
EPL-100-7_3	EPL-100-11_3	35.25	895	7.9
	EPL-100-18_2	37.25	946	
EPL-100-8_3	EPL-100-12_3	39.25	997	8.3
EPL-100-9_3	EPL-100-20_2 / EPL-100-13_3	41.25	1048	8.5
EPL-100-7_4	EPL-100-15_3	47.25	1200	9.0
EPL-100-8_4		53.25	1353	9.5
EPL-100-9_4	EPL-100-18_3	57.25	1454	9.9
EPL-100-7_5		59.25	1505	10.1

Consult Factory for Specifications of Models for Series 40 Level Gages

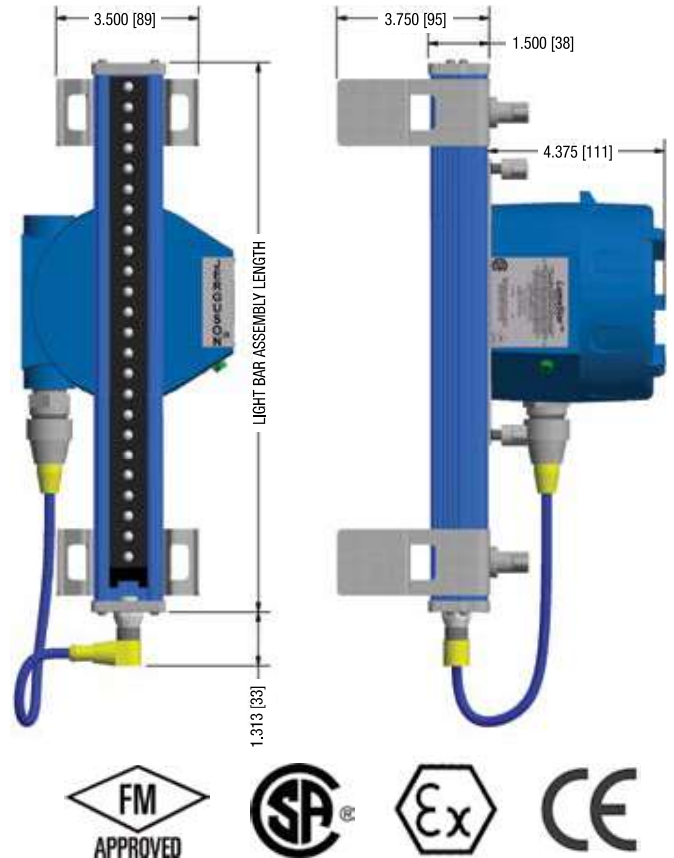

How to Specify LumaStar™ EPL-100

EPL-100- 9 - 1 - 1 - 1 -

LumaStar, Model EPL 100
115 or 230 VAC 50/60 Hz
NEMA 4, 4x, 7

Gage Window Size (1 thru 9 or 11 thru 20)

Prewired Terminal Connections
1 = FM/CSA Approved*, 115 VAC 50/60 Hz
2 = FM/CSA Approved*, 230 VAC 50/60 Hz
3 = ATEX Approved*, 115 VAC 50/60 Hz
4 = ATEX Approved*, 230 VAC 50/60 Hz
24 VDC option available, see page 34

Number of Gage Sections (1, 2, 3, 4)

Replacement 18" cable: V20509
(End-Fitting construction is Nickel-Plated Brass.)

Extension Cord for remote mount, 6.5 ft. length: V20601-6-5
(End-Fitting construction is Nickel-Plated Brass.)

Blank = Standard

D = Daisy Chain (for multiple single section light strips with connecting braided wire cable shielded for strength. Consult factory for maximum lengths and number of sections)

R = Remote Mount Power Supply (required for single section size 7 and smaller)

Mounting Brackets
1 = Universal Mounting Bracket for cover plates up to 3-1/2" in width. Use for all Jerguson Series 20/30/32/L10/300L/5/12/18 and competitive L/M/H series gages.
4 = Series 20/32 CS Covers NF Ext.
5 = Series 20/32 SS Covers NF Ext.
6 = Series 30/900# Boiler Water Gages
7 = Reliance FG450/900
8 = Reliance FG1500
9 = Series 40/1100/1600# Boiler Water Gages
11 = Jogler
12 = Reflex Gage

Note: Power Supply will be remote mounted for all single section size 7 and smaller illuminators.

LumaStar™ Offshore Illuminator Model EPL-316

All 316 Stainless Construction for Offshore & Other Severe Service Environments, Another Bright Ten-Year Solution

Jerguson® is pleased to announce the addition of the 316 Stainless Steel LED Gage Glass LumaStar™ Illuminator to the world's largest selection of level indication and control products. Jerguson's Model EPL-316 is approved for use in Class I, Div 1, Group B, C & D and Zone 2 environments and available in sizes up to 58" long with a single power supply. That means a four section size nine gage or five section size seven from a single power supply at less than 250 mA! Contact your local representative or a Jerguson Applications Engineer to configure an EPL-316 for your transparent glass level gages.

- 316 Stainless Steel Construction
- High Contrast
- *Superior Visibility Day or Night*
- Maintenance FREE
- Long Life ~100,000 hrs.
- No Heat Generation
- Field Upgradable
- *Fits any glass gage!*
- Eliminates "bulb-changes"
- Longest Field-of-View
- Covers up to 4 Size 9 Gage Sections or 5 Size 7 Gage Sections
- Explosion-Proof Stainless Steel Power Supply, Intrinsically Safe Lighting Circuit
- Pays for itself in electricity savings alone!
- IP66 Rating



EPL-316

FM/CSA Power Supply

Specifications – Model EPL-316

Power Supply:	115 or 230 VAC @ 50-60 Hz
Power Supply Weight:	7.4 lbs
Power Consumption:	<250 mA @ 120/240 VAC During Normal Operation Up to 400 mA max @ 120/240 VAC
Estimated Life:	100,000 Hours (continuous)
Agency Approvals:	FM and CSA Approvals <i>Class I, Div 1, Grps. B, C, & D, T4</i>
Wire Size:	Min 18 AWG / Max 12 AWG
Max Distance from Power Supply to Light Strip:	50 ft (15 m)
Ambient Temperature:	-40°F (-40°C) to 170°F (77°C)
Electrical Connection:	3/4" FNPT

24VDC option available,
see page 34

Liquid Level Gages

LumaStar™ EPL-316

LumaStar Model EPL-316		Overall Length		Light Assembly Weight lbs	Total Weight (including Remote Mount Power Supply)
Series 20/32	Series 300L	in	mm		
EPL-316-1_1		5.25	133	0.5	7.9
EPL-316-2_1		5.25	133	0.5	7.9
EPL-316-3_1		7.25	184	0.7	8.1
EPL-316-4_1		7.25	184	0.7	8.1
EPL-316-5_1		9.25	235	0.9	8.3
EPL-316-6_1	EPL-316-11_1	11.25	286	1.1	8.5
EPL-316-7_1		11.25	286	1.1	8.5
EPL-316-8_1	EPL-316-12_1	13.25	337	1.3	8.7
EPL-316-9_1	EPL-316-13_1	13.25	337	1.3	8.7
EPL-316-3_2	EPL-316-15_1	15.25	387	1.5	8.9
EPL-316-4_2		17.25	438	1.7	9.1
EPL-316-5_2	EPL-316-18_1	19.25	489	1.9	9.3
EPL-316-6_2	EPL-316-20_1	21.25	540	2.1	9.5
EPL-316-7_2	EPL-316-11_2	23.25	591	2.3	9.7
	EPL-316-12_2	25.25	641	2.5	9.9
EPL-316-8_2	EPL-316-13_2	27.25	692	2.7	10.1
EPL-316-9_2		29.25	743	2.9	10.3
EPL-316-6_3	EPL-316-15_2	31.25	794	3.1	10.5
EPL-316-7_3	EPL-316-11_3	35.25	895	3.5	10.9
	EPL-316-18_2	37.25	946	3.7	11.1
EPL-316-8_3	EPL-316-12_3	39.25	997	3.9	11.3
EPL-316-9_3	EPL-316-20_2/ EPL-316-13_3	41.25	1048	4.1	11.5
EPL-316-7_4	EPL-316-15_3	47.25	1200	4.7	12.1
EPL-316-8_4		53.25	1353	5.3	12.7
EPL-316-9_4	EPL-316-18_3	57.25	1454	5.7	13.1
EPL-316-7_5		59.25	1505	5.9	13.3

Consult Factory for Specifications of Models for Series 40 Level Gages

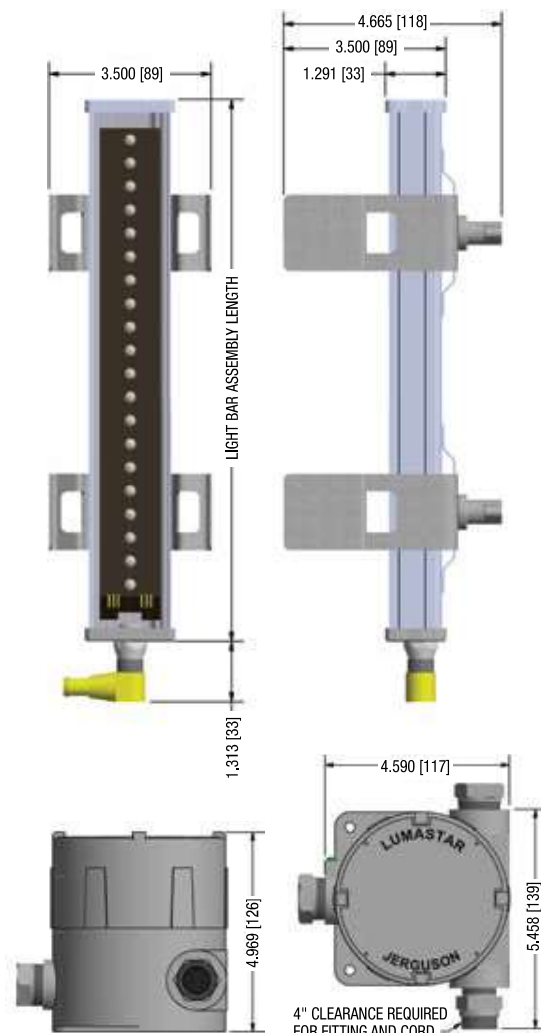

How to Specify LumaStar™ EPL-316

EPL-316-9-1-1-1-

LumaStar, Model EPL 316
115 or 230 VAC 50/60 Hz
NEMA 4, 4x, 7, IP66

Gage Window Size (1 thru 9 or 11 thru 20)

Prewired Terminal Connections

1 = FM/CSA Approved*, 115 VAC 50/60 Hz
2 = FM/CSA Approved*, 230 VAC 50/60 Hz
24 VDC option available, see page 34

Number of Gage Sections (1, 2, 3, 4)

Replacement 72" cable: V21249
(End-Fitting construction is 316/316L SS.)

Blank = Standard

D = Daisy Chain (for multiple single section light strips with connecting armored cable, consult factory for maximum lengths and number of sections)

Mounting Brackets

1 = Universal Mounting Bracket for cover plates up to 3-1/2" in width. Use for all Jerguson Series 20/30/32/L10/300L/5/12/18 and competitive L/M/H series gages.

Note: All Power Supplies are remote mounted.

LumaStar™ Illuminator Model EPL-100 & EPL-316

The Ten-Year Solution: Barrier Driven 24VDC Power Supply Option

Jerguson® LumaStar™ Illuminators' white LED design combines long-life performance with superior visibility for hazardous locations. Jerguson's illuminators with 24VDC power supplies are approved for use in Class I, Div 1, Group A, B, C & D environments and available in sizes up to 58" long with a single power supply. That means a four section size nine or five section size seven gage from a single power supply at less than 250 mA! Contact your local representative or a Jerguson Applications Engineer to configure an illuminator for your transparent glass level gages.



EPL-316



EPL-100

- 24VDC Power Supply
- Terminal Housing or Field-Wireable Connector Available
- High Contrast
- Superior Visibility Day or Night
- Maintenance FREE
- Long Life ~100,000 hrs.
- No Heat Generation
- Field Upgradable
- Fits any glass gage!
- Eliminates "bulb-changes"
- Longest Field-of-View
- Covers up to 4 Size 9 Gage Sections or 5 Size 7 Gage Sections
- Pays for itself in electricity savings alone!

Specifications – Model EPL-100 & EPL-316

Power Supply:	24VDC (Power supply not included as standard)
Estimated Life:	100,000 Hours (continuous)
Agency Approvals:	FM Approval <i>Class I, Div 1, Grps. A, B, C, & D, T4</i>
Wire Size:	Min 18 AWG / Max 12 AWG
Max Distance from Barrier to Light Strip:	1800 ft (548m)
Ambient Temperature:	-40°F (-40°C) to 140°F (60°C)
Electrical Connection:	7/8" diameter Panel opening for customer supplied cable gland or conduit fitting 3/4" FNPT (316SS Enclosure)

Power Supply Order Information

Note: A 24VDC Power Supply is not included with the products described above.

Part Number: V22185

Specifications

Output:	24VDC @ 420mA, 10W
Input:	90-264 VAC, 50/60 Hz, 0.3A Max
Type:	DIN Mount, NEC Class 2
Derating:	>55°C, 2.5%/°C
Operating Temp:	-25 to 71°C
Storage Temp:	-25 to 85°C
Humidity:	5 to 95% RH (Non-Condensing)

Liquid Level Gages

Field Terminal Connections

See page 31 or 33 for light assembly dimensions.



Field Wireable Connector
Material: Nickel-Plated Brass
for model EPL-100 & 316SS for
model EPL-316



Pin detail for Field Wireable
Connector



S24927: Terminal Enclosure;
FRP for model EPL-100

Field Terminal
Connection options
5 or 7



S24928: Terminal Enclosure;
316SS for model EPL-316

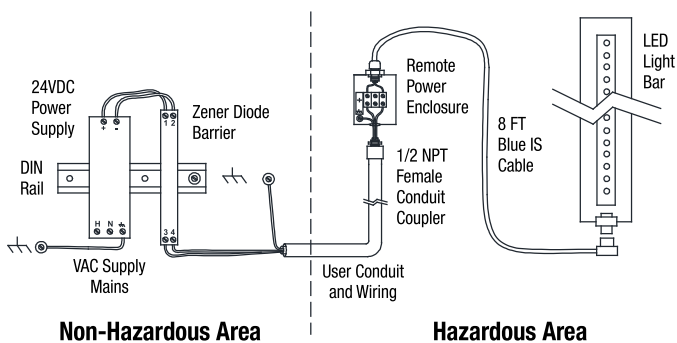

Non-Hazardous Area

Hazardous Area



How to Specify LumaStar™ EPL-100 & EPL-316

EPL-100-5-1-1-1-

100 = Aluminum Light Strip Housing
316 = Stainless Steel Light Strip Housing

Gage Window Size (1 thru 9 or 11 thru 20)

Field Terminal Connections

5 = Barrier + Terminal Enclosure¹

6 = Barrier + Field Wireable Connector¹

7 = Terminal Enclosure²

8 = Field Wireable Connection²

Number of Gage Sections (1, 2, 3, 4)

Replacement 8' cable, standard enclosure: V21906-8
(End-Fitting construction is Nickel-Plated Brass.)

Replacement 8' cable, 316SS enclosure: V21906-T-8
(End-Fitting construction is 316SS.)

Notes:

¹ Barrier provided is Turck item number MZB28P, or equal.

² Intrinsically safe barrier not included with these options.

All terminal enclosures are remote-mounted.

Blank = Standard

D = Daisy Chain (for multiple single section light strips with connecting braided wire cable shielded for strength. Consult factory for maximum lengths and number of sections)

Mounting Brackets

1 = Universal Mounting Bracket for cover plates up to 3-1/2" in width. Use for all Jerguson Series 20/30/32/L10/300L/5/12/18 and competitive L/M/H series gages.

4 = Series 20/32 CS Covers NF Ext.

5 = Series 20/32 SS Covers NF Ext.

6 = Series 30/900# Boiler Water Gages

7 = Reliance FG450/900

8 = Reliance FG1500

9 = Series 40/1100/1600# Boiler Water Gages

11 = Jogler

12 = Reflex Gage

Coating Options



FP-16 Coating

FP-16 (Standard)

Basic finish coating for carbon steel, forged or cast steel product components. Intended as a prime coat and provides protection in general environments.

FP-11

For coastal and offshore applications, this Three-Coat system is designed to give optimal service life in corrosive applications and environments.

- Inorganic zinc base coat
- Epoxy tie-coat
- Urethane top coat

This system includes 316SS fasteners and an acrylic protector that covers the exposed glass on the front (and back if transparent) of the gage. All components are coated prior to final gage assembly.

FP-11ZB

This option includes the same coating procedure as FP-11 except zinc-plated hardware is used instead of 316SS. Ideal for coastal areas or environments or as a more economical option to FP-11. This option does not include the acrylic protector as standard. All components are coated prior to final gage assembly.

FP-11CA

This option includes the same Three-Coat system as FP-11 except for the entire gage is painted after assembly for the most economical option when a superior level of protection is required. FP-11CA does not include the acrylic protector as standard.



FP-11 Coating

Custom Coatings

Jerguson can provide coatings per your project specifications. Contact an Applications Engineer for assistance.

Liquid Level Gages

Spare Parts 34mm

For Reflex or Transparent Standard Size 1 through 9 Glass

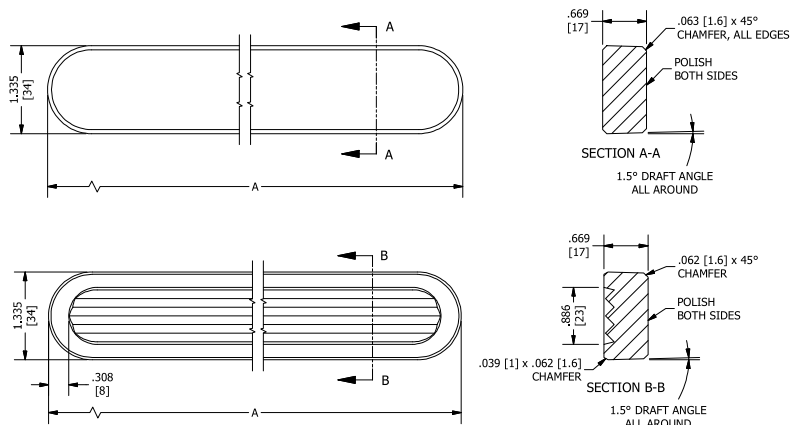

Glass Size	Dimension "A"	
	Inches	mm
1	4.500	115
2	5.500	140
3	6.500	165
4	7.500	190
5	8.625	220
6	9.875	250
7	11.000	280
8	12.625	320
9	13.375	340

Part Number	Material	Description
V-16756-X	Tempered Borosilicate	Standard Transparent Glass, compliant to BS3463, JIS B8211, DIN 7081. For temperature to 600°F, (316°C). When protected with Mica Shield can be used to 608°F (320°C).
V-16757-X	Tempered Borosilicate	Standard Reflex Glass, compliant to BS3463, JIS B8211, DIN 7081. For temperature to 600°F, (316°C).
V-16758-X	Tempered Borosilicate	High pressure Transparent Glass, compliant to BS3463, JIS B8211, DIN 7081. For temperature to 600°F, (316°C). When protected with Mica Shield can be used to 608°F (320°C). Polished to Maximum Flatness Tolerance 0.05 mm.
V-15841-X	Tempered Aluminosilicate	High Temperature Transparent Glass. For temperature to 800°F (427°C).
V-15840-X	Tempered Aluminosilicate	High Temperature Reflex Glass. For temperature to 800°F (427°C).
P-4452-X	Mica	Standard Mica Shield, Grade V2 / V4 .005 - .007" Thickness
P-8092-X	Mica	HQ Mica, Grade V2 / V4 .009 - .012" Thickness
P-6082-X	PCTFE	PCTFE Shield (formerly known as Kel-F). A sealing gasket is not used with this shield.
V-18980-X	Garlock® IFG 5500	Standard Gasket, suitable for most hydrocarbon service.
V-13143-X	SS Reinforced Graphite	Jerguson uses a laminated graphite with 0.002" 316SS sheet reinforcement. Jerguson has extensively tested un-reinforced graphite, and has found that it will not hold up to pressure cycling conditions, and is not recommended.
V-7858-X	PTFE	Low-Flow PTFE gasket, This is designed to reduce cold flow associated with solid PTFE.

Note: Replace "X" in all Part Numbers with the Glass Size. Parts supplied by sources other than Jerguson will void stamped pressure rating.

OEM Parts...
FAST!

Same Day Shipping on
Quality OEM Parts
clark-reliance.com/parts



Innovative Core Design Locating an Internal Ballcheck within a Metal Seated Valve

Patented design eliminates operator error, improves safety and reliability

- Improves safety by eliminating false level readings during commissioning
- Quarter turn position visible handle indicates open or closed
- Low emission certified to API 641 & ISO 15848-1
- Meets API Class V shut-off requirements
- 900# ANSI Pressure Rating
- All wetted components comply with NACE MR0103 and MR0175
- Clean-out port allows for quick inspection of internals or as a flushing port
- Lock-out / tag-out capable, standard

Innovative Design Guarantees Proper Commissioning

The Jerguson 360 Series valve is equipped with many features that elevate its performance above traditional style safety ballcheck valves. Designed to alleviate a widespread problem, the 360 Series' bypass mode seeks to remove guess work or operator error during commissioning. The quarter turn position — visible handle provides clear operation status and a locking pin to secure its position. **Patent # US9,377,113 B2**

Simplified Commissioning

As opposed to traditional ballcheck valves, it is impossible to get a false level reading with a 360 Series valve during commissioning. When using a traditional ballcheck valve and commissioning a gage assembly when there is already liquid present in the vessel, it is common for the operator to open the valve too quickly, causing the ballcheck to engage and the level gage to display a false level reading!

Simplified Commissioning: Watch for the video at www.jerguson.com/360-series



With liquid present in the vessel, open the top valve to By-Pass position.



Then open the bottom valve to the bypass position. Fluid will now flow through the valve and into the glass without seating the ballcheck.

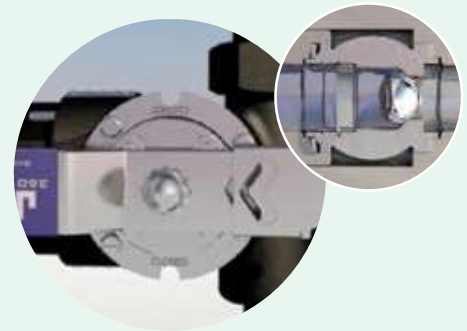

Once the level stops rising, move both valves to the run position. Now, the valves are ready for normal operation. If your level gage is not maintained properly or a leak occurs, the ballcheck will engage and isolate the gage from the vessel.

Liquid Level Valves

How to Specify 360 Series Safety Ballcheck Valves

Gage Connection Type

Code	Description
3S	Set, Non-Union Gage Connection
4S	Set, Union Gage Connection
3T	Top Valve, Non-Union Gage Connection
3B	Bottom Valve, Non-Union Gage Connection
4T	Top Valve, Union Gage Connection
4B	Bottom Valve, Union Gage Connection

Body Material

Code	Description
A	A105N Carbon Steel
T	A182 316/316L Stainless Steel
LC	Hastelloy C276

Trim Material

Code	Description
1	316SS Nitride Coated Seat & Ball; Inconel Stem
2	Hastelloy C276 Ball & Stem; Teflon Seat

Process Connection

Style	Code	Description	Size	Code	Description	Sizes Valid with Styles
A	FNPT	04	1/2" (DN15)	A, B, C, D, F, G		
B	FSW	06	3/4" (DN20)	A, C, D, F, G		
C	MNPT	08	1" (DN25)	C, D, F, G		
D	MSW	12	1-1/2" (DN40)	F, G		
F	RF ASME Flange	16	2" (DN50)	F, G		
G	RF DIN Flange	00	N/A	K		
K	No Connection					

364S-A-1-A04-A04-A04-

Options

Code	Description
Blank	Standard
WN	Weld Neck Flanges
RJ	Ring Joint Flanges
SG	Spherical Union Gage Connection

Clean-Out Connection Size

Code	Description	Note
A04	1/2" FNPT	Factory Default when 1/2" size vent/drain is specified
A06	3/4" FNPT	Factory Default when 3/4" size vent/drain is specified

*Contact factory for special connections

Vent or Drain Connection

Style	Code	Description	Size	Code	Description	Sizes Valid with Styles
A	FNPT	04	1/2" (DN15)	A, B, F, G		
B	FSW	06	3/4" (DN20)	A, B, F, G		
F	RF ASME Flange	08	1" (DN25)	F, G		
G	RF DIN Flange	12	1-1/2" (DN40)	F, G		
K	No Connection	16	2" (DN50)	F, G		
		00	N/A	K		

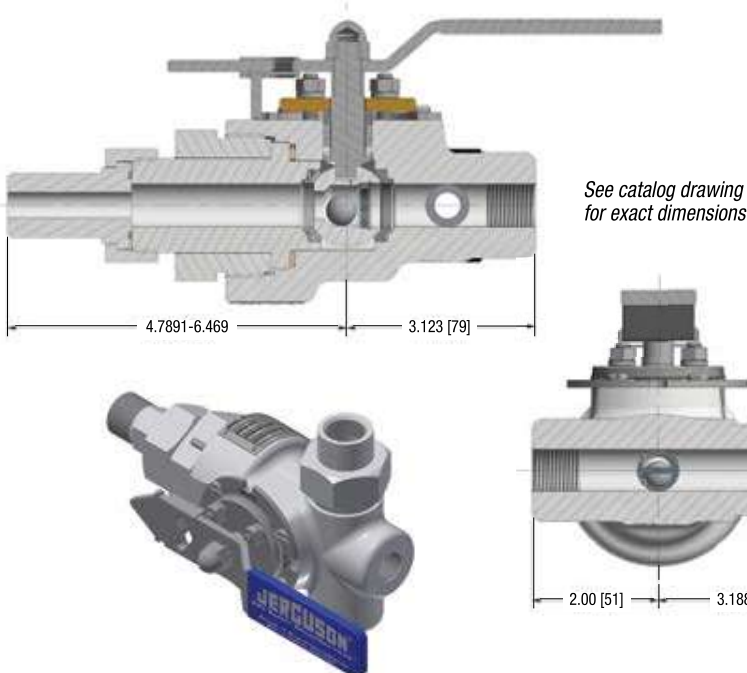

Carbon Steel

Series 360 Temperature / Pressure

Temperature		Pressure			
°F	°C	PSI	BarG	Kg/cm ²	kPaG
100	38	2220	153	156	15306
200	93	2035	140	143	14031
300	149	1965	135	138	13548
400	204	1900	131	134	13100
500	260	1810	125	127	12480
600	316	1705	118	120	11756
700	371	1590	110	112	10963
800	427	1235	85	87	8515

Not recommended for steam service

316SS

Series 360 Temperature / Pressure

Temperature		Pressure			
°F	°C	PSI	BarG	Kg/cm ²	kPaG
100	38	2160	149	152	14893
200	93	1860	128	131	12824
300	149	1680	116	118	11583
400	204	1540	106	108	10618
500	260	1435	99	101	9894
600	316	1355	93	95	9342
700	371	1305	90	92	8998
800	427	1265	87	89	8722

Not recommended for steam service



Offset Pattern



Straight Pattern

Traditional Safety Ballcheck Valves

Jerguson® Safety Ballcheck Valves are an essential component of a glass level gage assembly. A wide selection of optional features permits a high degree of customization to tackle even the most challenging applications. Safety Ballcheck Valves are available in both straight and offset pattern with integral, union, or bolted bonnet arrangements for application pressures ranging up to 10,000 PSI.

Enhanced Plant Safety

In the unlikely event of a catastrophic glass or gasket failure, the pressure differential will cause the ballcheck to seat, instantaneously isolating the gage from the vessel. This will reduce the potential for exposure to the process fluid, physical injury, and also minimize the rapid loss of product!

Easy Maintenance

Safety Ballcheck Valves provide a means to isolate the gage from the process fluid. This allows the level gage assembly to be drained and removed from service for routine maintenance. Offset valves mounted on top/bottom of a gage offer the added benefit of permitting an unrestricted opening through the vent or drain port of the valve to allow cleaning of the glass.

Rugged Construction

Valve bodies are created from forged steel to provide prolonged trouble-free service. All materials are listed in ASME or ASTM to guarantee mechanical and chemical properties.

Commissioning: Watch for the video at www.jerguson.com/safety_ballcheck_valves/



Commission Procedure

Step 1

Open the top valve 1/4 to 1/2 turn. It is best practice to always open the top valve first when commissioning any level gage.

Step 2

Open the bottom valve 1/4 to 1/2 turn to allow liquid to flow into the gage. Only slightly opening the valve keeps the stem tip engaged with the ballcheck to prevent it from seating. Wait until the level stops rising before proceeding.

Step 3

Fully open the top valve, and then the bottom valve. The stem is now retracted into the seat cavity. If your level gage is not maintained properly or a leak occurs, the ballcheck will engage and isolate the gage from the vessel.

Integral Bonnet Valves

140 Series for Reflex or Transparent Flat Glass Gages



No. 143



No. 144



No. 146



No. 147

Jerguson® No. 140 Series Valves provide long trouble-free service at economical cost. Their design incorporates such quality features as stainless steel stems and ballchecks. A comprehensive selection of connections provides the versatility required to conform to most piping requirements. Optional features permit a high degree of customization to meet very specific demands.

NO. 140 SERIES VALVES

The series consists of the following valves:

No. 143 – straight pattern with non-union gage connection

No. 144 – straight pattern with union gage connection

No. 146 – offset pattern with non-union gage connection

No. 147 – offset pattern with union gage connection

PRESSURE RATINGS

Carbon & Stainless Steel Valves

Series 140 Temperature / Pressure

Temperature		Pressure			
°F	°C	PSI	BarG	Kg/cm ²	kPaG
100	38	2400	165.5	168.7	16547
200	93	2246	154.9	157.9	15487
300	149	2092	144.3	147.1	14426
400	204	1938	133.6	136.3	13365
500	260	1785	123.0	125.5	12304
600	316	1631	112.4	114.7	11243
700	371	1477	101.8	103.8	10183
800	427	1323	91.2	93.0	9122

Not recommended for steam service

STANDARD FEATURES

Safety Shut-Off: All No. 140 Series Valves are equipped with stainless steel ballchecks upstream from the seats which instantaneously shut-off flow of fluid in case of gage failure. The ball may be omitted on request.

Integral Bonnet: The bonnet on all No. 140 Series Valves screws directly onto the outside of the forged body. The inner area bears on the packing gland.

Union Tank Connection: Series 140 Valves are equipped with union tank connections which permit simple installation and easy access to the ballcheck. A spring clip secures the ballcheck in place so that it does not fall out when the union tank connection is removed.

Union Gage Connection: Nos. 144 and 147 are furnished with a union gage connection which allows a top and bottom connected gage to be turned to any desired angle for convenient visibility. It also makes possible removal of the gage without removing the valves or draining the liquid from the vessel – a feature which saves time when the gages must be cleaned or maintained.

Offset Pattern: Nos. 146 and 147 valve bodies are designed so that the gage connections are offset 7/8" from the centerline of the vessel connections. By removing the vent or drain plug, the interior of a top and bottom connected gage may be swabbed without disassembly.

Union Bonnet Valves

Series 60 for Reflex or Transparent Flat Glass Gages



No. 63



No. 64



No. 66



No. 67

- Regrindable, renewable seat

Jerguson® No. 60 Series Valves are designed and built to the highest standards. Quality features include stainless steel stems, seats, and ballcheck, regrindable and renewable seats. A wide selection of optional features permit a high degree of customizing to meet very specific demands.

NO. 60 SERIES VALVES

The series consists of the following valves:

No. 63 – straight pattern with non-union gage connection

No. 64 – straight pattern with union gage connection

No. 66 – offset pattern with non-union gage connection

No. 67 – offset pattern with union gage connection

PRESSURE RATINGS

Carbon & Stainless Steel Valves

Series 60 Temperature / Pressure

Temperature		Pressure			
°F	°C	PSI	BarG	Kg/cm ²	kPaG
100	38	4000	275.8	281.2	27579
200	93	3615	249.3	254.2	24928
300	149	3231	222.8	227.2	22276
400	204	2846	196.2	200.1	19624
500	260	2462	169.7	173.1	16973
600	316	2077	143.2	146.0	14321
700	371	1693	116.7	119.0	11670
800	427	1308	90.2	92.0	9018

Saturated steam rating 600 WSP

STANDARD FEATURES

Safety Shut-Off: All No. 60 Series Valves are equipped with a stainless steel ballchecks located upstream from the seat which instantaneously shut-off flow of fluid in case of gage failure. The ball may be omitted on request.

Union Tank Connection: Series 60 Valves are equipped with union tank connections which permit simple installation and easy access to the ballcheck. A spring clip secures the ballcheck in place so that it does not fall out when the union tank connection is removed.

Union Gage Connection: Nos. 64 and 67 are furnished with a union gage connection which allows a top and bottom connected gage to be turned to any desired angle for convenient visibility. It also makes possible removal of the gage without removing the valves or draining the liquid from the vessel - a feature which saves time when gages must be cleaned or maintained.

Offset Pattern: Nos. 66 and 67 valve bodies are designed so the gage connections are offset 7/8" from the centerline of the vessel connections. By removing the vent or drain plug, the interior of a top and bottom connected gage may be swabbed without disassembly.

Convertible to Quick Closing: No. 60 Series Valves may be converted from plain to quick-closing, in the field, by replacement of sleeve, stem and packing. Note that quick-closing stems can make it more difficult to properly commission a gage assembly when there is already liquid present in the vessel.

Regrindable, Renewable Seat: The seat may be regrind using the sleeve as a guide. The seat may be removed or replaced using a standard 5/8" socket wrench

70BL Series Safety Ballcheck Valves

Liquid Level Valves

600# ANSI Rated Valves, Bolted Bonnet, OS&Y Construction

70BL/XL Series for Reflex or Transparent Flat Glass Gages



No. 73BL/73XL



No. 74BL/74XL



No. 76BL/76XL



No. 77BL/77XL

- Low Emission to API 624
- Re grindable, renewable seat
- Bolted bonnet
- Backseating stem

Built to ANSI, API Standards

Jerguson® No. 70BL and 70XL Series Valves are designed for use with flat glass gages, instrument piping and for other applications requiring a rugged, lightweight valve. Pressure and temperature ratings exceed those of ANSI/ASME 600# class. Refer to table below for complete ratings.

PRESSURE RATINGS

Carbon Steel Valves

Temperature		Pressure			
°F	°C	PSI	BarG	Kg/cm ²	kPaG
100	38	3000	206.8	210.9	20684
200	93	2723	187.8	191.5	18775
300	149	2446	168.7	172.0	16867
400	204	2169	149.6	152.5	14958
500	260	1893	130.5	133.1	13049
600	316	1616	111.4	113.6	11140
700	371	1339	92.3	94.1	9231
800	427	1062	73.2	74.7	7322

Saturated steam rating 750 WSP

Stainless Steel Valves

Temperature		Pressure			
°F	°C	PSI	BarG	Kg/cm ²	kPaG
100	38	2100	144.8	147.6	14479
200	93	1908	131.5	134.1	13153
300	149	1715	118.3	120.6	11827
400	204	1523	105.0	107.1	10502
500	260	1331	91.8	93.6	9176
600	316	1139	78.5	80.0	7850
700	371	946	65.2	66.5	6524
800	427	754	52.0	53.0	5199

Saturated steam rating 750 WSP

STANDARD FEATURES

OS&Y + Backseating Stem: The yoke supports the stem away from the valve body so the threaded portion of the stem is unaffected by heat and does not come in contact with process fluids. The stem has a backseating area which allows repacking the valve under pressure and protects the packing from the fluid.

Regrindable, Renewable Seat: The seat may be reground, removed or replaced using a standard 5/8" socket wrench.

Union Gage Connection: Nos. 74BL and 77BL are furnished with a union gage connection which allows a top and bottom connected gage to be turned to any desired angle for convenient visibility. It also makes possible the removal of the gage without removing the valves or draining the liquid from the vessel — a feature which saves time when gages must be cleaned or maintained.

Offset Pattern: Nos. 76BL and Nos. 77BL valve bodies are designed so the gage connections are offset 7/8" from the centerline of the vessel connections. By removing the vent or drain plug, the interior of a top and bottom connected gage may be swabbed without disassembly.

Safety Shut-Off: All No. 70BL Series Valves are equipped with stainless steel ballchecks upstream from the seats which instantaneously shuts-off flow of fluid in case of gage failure.





No. 73



No. 74



No. 76



No. 77

900# ANSI Rated Valves, Bolted Bonnets, OS&Y Construction

70 Series for Reflex or Transparent Glass Gages

- Low Emission to API 624
- Re grindable, renewable seat
- Bolted bonnet
- Backseating stem

Jerguson® No. 70 Series Valves are designed for use with flat glass gages, instrument piping and for other applications requiring a rugged valve. Pressure and temperature ratings exceed those of ANSI/ASME 900# class. Refer to table below for complete ratings.

No. 70 Series Valves

The series consists of the following valves:

- No. 73** – straight pattern with non-union gage connection
- No. 74** – straight pattern with union gage connection
- No. 76** – offset pattern with non-union gage connection
- No. 77** – offset pattern with union gage connection

PRESSURE RATINGS

Stainless Steel Valves

Series 70 Temperature / Pressure

Temperature		Pressure			
°F	°C	PSI	BarG	Kg/cm ²	kPaG
100	38	4000	275.8	281.2	27579
200	93	3615	249.3	254.2	24928
300	149	3231	222.8	227.2	22276
400	204	2846	196.2	200.1	19624
500	260	2462	169.7	173.1	16973
600	316	2077	143.2	146.0	14321
700	371	1693	116.7	119.0	11670
800	427	1308	90.2	92.0	9018

Saturated steam rating 1500 WSP

STANDARD FEATURES

OS&Y + Backseating Stem: The yoke supports the stem away from the valve body so the threaded portion of the stem is unaffected by the heat and does not come in contact with process fluids. The stem has a backseating area which allows repacking the valve under pressure.

Regrindable Renewable Seat: The seat may be reground or replaced using a standard 5/8" socket wrench.

Union Gage Connection: Nos. 74 and 77 are furnished with a union gage connection which allows a top and bottom connected gage to be turned to any desired angle for convenient visibility. It also makes possible the removal of the gage without removing the valves or draining the liquid from the vessel — a feature which saves time when gages must be cleaned or maintained.

Offset Pattern: Nos. 76 and Nos. 77 valve bodies are designed so the gage connections are offset 7/8" from the centerline of the vessel connections. By removing the vent or drain plug, the interior of a top and bottom connected gage may be swabbed without disassembly.





No. 84H



No. 86H



No. 87H

900# ANSI Rated Valves, Bolted Bonnets, OS&Y Construction

80H Series for Reflex or Transparent Glass Gages

- Stellite hard-faced seat & stem
- Bolted bonnet
- Backseating stem
- Spiral-wound gasket union gage connections

Jerguson® No. 80H Series Valves are designed for use with flat glass gages, instrument piping and for other applications requiring a rugged valve. Pressure and temperature ratings exceed those of ANSI/ASME 900# class. Refer to table below for complete ratings.

No. 80H Series Valves

The series consists of the following valves:

- No. 84H** – straight pattern with union gage connection
- No. 86H** – offset pattern with non-union gage connection
- No. 87H** – offset pattern with union gage connection

PRESSURE RATINGS

Material	Pressure Ratings Nos. 84H & 87H Valves
Carbon Steel	6000 PSI (413 BarG) @ 100°F (38°C) 3550 PSI (245 BarG) @ 750°F (399°C)
316SS	6000 PSI (413 BarG) @ 100°F (38°C) 3920 PSI (270 BarG) @ 750°F (399°C)

STANDARD FEATURES

OS&Y + Backseating Stem: The yoke supports the stem away from the valve body so the threaded portion of the stem is unaffected by the heat and does not come in contact with process fluids. The stem has a backseating area which allows repacking the valve under pressure.

Renewable Seat: The seat may be removed or replaced using a standard 3/4" socket wrench. (not regrindable)

Union Gage Connection: Nos. 84H and 87H are furnished with a union gage connection which allows a top and bottom connected gage to be turned to any desired angle for convenient visibility. It also makes possible the removal of the gage without removing the valves — a feature which saves time when gages must be cleaned or maintained.

Offset Pattern: Nos. 86H and 87H valve bodies are designed so the gage connection is offset 7/8" from the centerline of the vessel connection. By removing the vent or drain plug, the interior of a top and bottom connected gage may be swabbed without disassembly.



No. 86HO

* 86HO looks identical to 86H but contains internal O-Rings.

High Pressure Valve, Bolted Bonnet, OS&Y Construction

86HO for Reflex or Transparent Flat Glass Gages

- Working pressure to 10,000 psi
- Reciprocating backseating stem

Jerguson® No. 86HO Valves are designed and manufactured for use with flat glass gages, instrument piping and for other applications requiring a rugged valve in the higher pressure ranges.

No. 86HO – with Viton® O-Ring between bonnet and body and under renewable seat and drain plug

Materials

Body	Seat	Stem	Loose Knob	Sleeve
Carbon Steel	416SS	416SS	Stellite #3 or #6	416SS
316SS	316SS	316SS	Stellite #3 or #6	316SS

Standard Connections

Vessel: 3/4" or 1" male socket or flanged to requirements

Gage: 1/2" female socket weld only

Vent/Drain: O-Ring sealed plug, or 1/2" socket weld

PRESSURE RATINGS

Carbon & Stainless Steel Valves

Series 86HO Temperature / Pressure

Temperature		Pressure			
°F	°C	PSI	BarG	Kg/cm ²	kPaG
100	38	10000	689.5	703.1	68948
200	93	10000	689.5	703.1	68948
300	149	10000	689.5	703.1	68948
400	204	10000	689.5	703.1	68948

Not recommended for steam service.

STANDARD FEATURES

When a Viton O-Ring is used in place of the spiral wound gasket, this valve is suitable for pressures up to 10,000 PSI at 400°F.

It is designed specifically to be compatible with Jerguson's 10,000 PSI Series 51 Flat Glass Gage.

OS&Y + Backseating Stem: The yoke supports the stem away from the valve body so the threaded portion of the stem is unaffected by the heat and does not come in contact with process fluids. The stem has a backseating area which allows repacking the valve under pressure.

Loose Knob, Backseating Stem: The disc on the stem is keyed and free rotating. This assures perfect seating and eliminates the possibility of galling at the seat. Acme threads are used to assure easy operation. When the stem is backed out to its limit the knob on the stem seats against the bonnet sleeve allowing the stem to be repacked when the valve is under pressure.

Renewable Seat: The seat may be removed or replaced using a standard 3/4" socket wrench. (not regrindable)

Offset Pattern: The 86HO valve body is designed so the gage connection is offset 7/8" from the centerline of the vessel connection. By removing the vent or drain plug, the interior of a top and bottom connected gage may be swabbed without disassembly.



No. 93



No. 94

Jacketed Valves for Use with Heated or Cooled Gages

90 Series for Reflex or Transparent Flat Glass Gages

- Plain or quick closing stem
- Regrindable, renewable seat
- Union Bonnet

Jerguson® No. 90 Series Valves are designed especially for use with heated or cooled gages. A jacket surrounding the valve permits circulation of the heating or cooling medium. Four 1/4" holes are tapped into the jacket for connection to the heating-cooling supply and / or tracing tube.

No. 90 Series Valves

The series consists of the following valves:

No. 93 – Jacketed valve with union vessel connection and non-union gage connection

No. 94 – Jacketed valve with union vessel connection and union gage connection

PRESSURE RATINGS

Jacket 600 WSP

Carbon & Stainless Steel Valves

Series 90 Temperature / Pressure

Temperature		Pressure			
°F	°C	PSI	BarG	Kg/cm ²	kPaG
100	38	4000	275.8	281.2	27579
200	93	3615	249.3	254.2	24928
300	149	3231	222.8	227.2	22276
400	204	2846	196.2	200.1	19624
500	260	2462	169.7	173.1	16973
600	316	2077	143.2	146.0	14321
700	371	1693	116.7	119.0	11670
800	427	1308	90.2	92.0	9018

Saturated steam rating 600 WSP

STANDARD FEATURES

Safety Shut-Off: All No. 90 Series Valves are equipped with a stainless steel ballcheck located upstream from the seat which instantaneously shut-off flow of fluid in case of gage failure. The ball may be omitted on request.

Regrindable, Renewable Seat: The seat may be reground using the sleeve as a guide. The seat may be removed or replaced using a standard 5/8" socket wrench

Union Tank Connection: Series 90 Valves are equipped with union tank connections which permit simple installation and easy access to the ballcheck. A spring clip secures the ballcheck in place so that it does not fall out when the union tank connection is removed.

Union Gage Connection: No. 94 is furnished with a union gage connection which allows a top and bottom connected gage to be turned to any desired angle for convenient visibility. It also makes possible removal of the gage without removing the valves or draining the liquid from the vessel — a feature which saves time when gages must be cleaned or maintained.

Valve Options

Standard Safety Ballcheck Valve Materials of Construction

Carbon Steel Body with 416 / 440 Stainless Steel Trim
 • To -20°F (-28°C)

Low Temp Carbon Steel Body with 316 Stainless Steel Trim
 • To -50°F (-45°C)
 • Charpy Impact Tested

316 Stainless Steel Body & Trim Wetted Parts Only (Parts in Contact)
 • To -325°F (-198°C)
 • Dual Rated 316/316LSS

All Parts 316 Stainless Steel Body & Trim
 Contact Factory for special alloy materials

Union Tailpiece Options

Spiral Wound Gasket (available on both vessel & gage connections) – Recommended for severe service for enhanced sealing reliability

Spherical Union Connections (available on both vessel & gage connections) – Can adjust up to 10 degrees of misalignment, which results in +/- 3/4" when used on side-connected gage assemblies.

Adjustable Tailpiece – Similar to the spherical unions can aid in the slight misalignment of vessel taps

Other Options

Vertical Rising Ballcheck – Used for compliance with ASME Section I Boiler Code (lower offset end connected valves only).

Quick Closing Stems – Allow for rapid isolation of the level gage assembly from the tank. This option is typically used in steam service in conjunction with vertical rising ballcheck in the lower valve as it can be difficult to commission a conventional ballcheck valve with quick-closing stem threads

Stellite Hardfacing (seat / stem) – Superior corrosion protection, and hardening of wear parts.

Valve Packing Options

Carbon Fiber
 Teflon
 Grafoil
 Flexible Graphite w/ Inconel
 • **Low Emission** (70BL / 70 Series only)

Valve Trim Options

416SS (standard)
 316SS - Required for NACE Compliance
 Monel
 Alloy 20

Connection Options

Union Vessel Connection (140, 60)
 Solid Shank (70BL, 70, 86)
 Threaded - 1/2" or 3/4" as standard
 Socket Weld - 1/2" or 3/4" as standard
 Flanged – Slip On, Socket Weld, Weld Neck

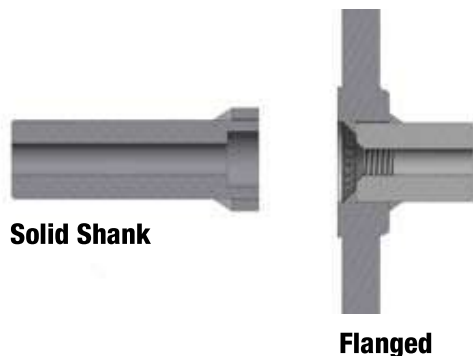

Solid Shank

Flanged



1/2", 3/4", or 1" MNPT

1/2", 3/4", or 1" MSW

1/2" or 3/4" MNPT or MSW Spherical

1/2" or 3/4" FNPT

1/2" FSW

1/2" FNPT or FSW Spherical

Liquid Level Valves



Tubular Glass Gage

Tubular Glass Gages V-Series Bronze Gage Valves

Jerguson® Gage & Valve offers a complete line of brass, bronze and stainless steel tubular glass gage valves for economical service.

The standard straight-through flow design features a durable cast aluminum wheel. Connections of 1/2 or 3/4 inch NPT are available for attaching the valve to the vessel.

Highly durable Pyrex® gage glass is available with outside diameters of 5/8 or 3/4 inch. Visibility lengths vary as required. Guard rods are recommended to protect the glass from damage, and for added safety.

Series VA Automatic

Model No. VA-991 5/8" Dia. Glass, 1/2" NPT Vessel Conn.
Model No. VA-902 3/4" Dia. Glass, 3/4" NPT Vessel Conn.

These tubular glass gage valves feature bronze body construction. They come complete with corrosive-resistant ballchecks for automatic closure in the event of glass breakage. This ensures safety and prevents the loss of fluid. Maximum working pressure is 400 PSI @ 100°F, or 200 PSI @ 400°F.

NOTE: Pressure ratings will vary depending upon temperature, glass length, and glass type. Refer to table for complete ratings.

Series VB Non-Automatic

Model No. VB-991 5/8" Dia. Glass, 1/2" NPT Vessel Conn.
Model No. VB-902 3/4" Dia. Glass, 3/4" NPT Vessel Conn.

These bronze valves are similar to above models. However, ballchecks are not standard, thus making operation non-automatic. A 1/4" needle drain valve in the lower unit accommodates a breakage condition. Either a 1/4" lower arm ball or a petcock is available upon request. Sizes, packing materials and working pressures are identical to Series VA Models.

Series VC Automatic

Model No. VC-991 5/8" Dia. Glass, 1/2" NPT Vessel Conn.
Model No. VC-902 3/4" Dia. Glass, 3/4" NPT Vessel Conn.

Conforming to ASME power-boiler code requirements, these gage valves feature stainless steel ballchecks in both upper and lower units. This provides automatic closure in the event of glass breakage and requires the ballcheck in the lower valve to rise vertically to its seat. A safety handle is also provided for manual operation of the 5/16" diameter drain valve. This valve is of the full-flow ball valve design.

The valve body is constructed of rugged, heavy pattern bronze. Standard packing materials are wear-resistant Teflon®-PTFE. Maximum working pressure is rated at 500 PSI @ 100°F, or 250 PSI @ 400°F.

NOTE: Pressure ratings will vary depending on temperature, glass length, and glass type. Refer to table for complete ratings.

Series VE Non-Automatic

Model No. VE-991 5/8" Dia. Glass, 1/2" NPT Vessel Conn.
Model No. VE-902 3/4" Dia. Glass, 3/4" NPT Vessel Conn.

These gage valves are identical in every respect to above models, except for the non-automatic design. Ballchecks are not included.

NOTE: Plastic protector enclosures are not available for the above glass gages.

Maximum Working Pressures with High Pressure Glass

Glass Length (inches)	Glass Diameter (inches)	Bronze Series VA & VB		Bronze Series VC & VE		Glass Types (to come)
		100°F Max PSI	400°F Max PSI	100°F Max PSI	400°F Max PSI	
10	5/8	400	200	420	250	
	3/4	400	200	410	250	
12	5/8	400	200	410	250	
	3/4	400	200	400	250	
18	5/8	360	200	360	250	
	3/4	355	200	355	250	
20	5/8	350	200	350	250	
	3/4	345	200	345	250	
24	5/8	320	200	320	250	
	3/4	315	200	315	250	
30	5/8	280	*	280	*	
	3/4	275	*	275	*	
36	5/8	245	*	245	*	
	3/4	240	*	240	*	
40	5/8	230	*	230	*	
	3/4	225	*	225	*	
48	5/8	195	*	195	*	
	3/4	190	*	190	*	
60	5/8	150	*	150	*	
	3/4	145	*	145	*	
72	5/8	100	*	100	*	
	3/4	100	*	100	*	

*Not Recommended

Cut Lengths for Tubular Glass

Model	Centerline factor to calculate exact lengths					
	Visible Range		Tubular Glass		Guard Rods	
	in	mm	in	mm	in	mm
VA-991	-2.875	-73	-1.250	-32	0.750	19
VA-902	-2.875	-73	-1.250	-32	0.750	19
VB-991	-2.875	-73	-1.250	-32	0.750	19
VB-902	-2.875	-73	-1.250	-32	0.750	19
VC-991	-4.000	-102	-2.000	-51	-0.750	-19
VC-902	-4.000	-102	-2.000	-51	-0.750	-19
VE-991	-4.000	-102	-2.000	-51	-0.750	-19
VE-902	-4.000	-102	-2.000	-51	-0.750	-19

Types & Connections to Suit All Requirements



No. 125
*Straight pattern -
bar stock body
and seat*



No. 136
*Offset pattern
forged body
integral bonnet
and seat*



No. 56
*Offset pattern
forged body union
bonnet renewable
seat*

These tubular glass gage cocks represent years of experience in the manufacture of gage cocks and offer a variety of types and connections to suit all requirements.

PRESSURE RATINGS

Maximum working pressure dependent on length and resultant pressure rating of glass. See table.

No. 125 Standard

- 1/2" & 3/4" non-union rigid vessel connection.
- Straight pattern body.
- Plain closing stem.
- Stainless steel ballcheck to shut-off in event of tube breakage.
- Valves can be used with 4 guard rods.

No. 136 Standard

- 1/2" or 3/4" NPT union gage connection.
- Integral bonnet.
- Plain closing stem only.
- Valves can be used with heavy duty plastic protector or 4 guard rods.
- Stainless steel ballcheck to shut-off flow in event of tube breakage.
- Offset bodies permit swabbing of glass when plugs are removed from vent and drain.

No. 56 Standard

- 1/2" or 3/4" NPT union gage connection.
- Renewable regrindable stainless steel seat.
- Sleeve construction to allow for optional:
 - (a) quick closing - 90° from full open to tight closing using lever and chain;
 - (b) backseating stem to protect packing
- Valves can be used with heavy-duty plastic protector or 4 guard rods.
- Stainless steel ballcheck to shut-off flow in event of tube breakage.
- Offset bodies permit swabbing of glass when plugs are removed from vent and drain.

Cut Lengths for Tubular Glass

Model	Centerline factor to calculate exact lengths					
	Visible Range		Tubular Glass		Guard Rods	
	in	mm	in	mm	in	mm
56	-4.625	-117	-1.375	-35	-2.125	-54
136	-4.625	-117	-1.375	-35	-2.125	-54
125	-3.750	-95	-1.875	-48	-2.125	-54

Liquid Level Valves

Options for #136 & #56 Tubular Gage Assemblies



Plastic Tubular Guards

Standard Guard Rods

Guard Rods

- Standard
- Plastic Tubular

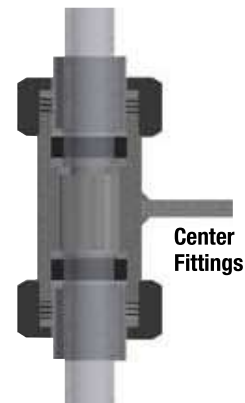

Center Fittings

Center Fittings

- Recommended for longer assemblies
- Max 144" centers with 2 center fittings
 - 136 / 56 valves, 5/8" or 3/4" OD Glass
 - CS/316SS and All 316SS options



Teflon® Packing

EPDM Packing

Glass Packing

- Buna
- Teflon®
- EPDM – black rubber



Tubular Glass

Tubular Glass Options

- Heat Treated High Pressure - 5/8" & 3/4"
- Pyrex® Red-Line - 5/8" & 3/4"
- Pyrex Heavy Wall - 3/4" Only
- Polycarbonate - 3/4" Only
- PCTFE - 3/4" Only



Instrumentation & Control

JERGUSON®



Level Gages
Magnetic Level Gages
Switches & Valves

JACOBY-TARBOX®



Sight Flow Indicators
Sight Windows
Eductors

Reliance®



Boiler Level Gages
Remote Level Indicators
Boiler Safety Instruments

Filtration & Purification

**ANDERSON®
Separator**



Gas Coalescing & Filtration
Steam Separators & Traps
Liquid Particle Filtration

**Enervac™
INTERNATIONAL ULC**



Transformer Oil Purification
SF6 Equipment
Air Dryers

**OIL
FILTRATION
SYSTEMS®**



Vacuum Dehydrators
Varnish Removal Systems
Hi & Low Flow Filter Skids

Elements, Internals, Parts & More



www.clark-reliance.com | www.clark-reliance.com/parts

CHPOLANSKY

3 Rue Angiboust 91460 Marcoussis - France Phone : +33(0)1.69.80.15.00
www.chpolansky.fr

JERGUSON®

A PRODUCT OF CLARK-RELIANCE

16633 Foltz Parkway, Strongsville, OH 44149 USA Phone: +1 440.572.1500 Fax: +1 440.238.8828
www.jerguson.com



ISO 9001:2000